



Human performance and limitations in aviation: physiological and behavioural aspects*

Guido Li Volsi^{1†} , Stefano Arcifa^{1‡}, Alessandro V. Aruta^{1§}, Alfio Distefano^{1¶},
Alfio Gulizzi^{1||}, Andrea Libra^{1**}, Carmelo Maimone^{1††}, Stefano Mirulla^{1‡‡},
Antonio Mongioì^{1§§}, Dario Nocita^{1¶¶}, Filippo Papale^{1***}, Giovanni Patti^{1†††},
Ferdinando Quattrocchi^{1‡‡‡}, Paolo Romano^{1§§§}

¹*Aero Club - Flight School - Catania; Approved Training Organization 0043, Italy;
International Airport of Catania, Italy*

Summary

Human flight, since its origins, has been seen as an appropriate scenario for a whole series of issues related to the physics of flight, the architecture and safety of aircraft, as well as the physiology and psychology of pilots and passengers. During the First

*Paper presented by the member Guido Li Volsi in the session of February 25, 2022.

†E-mail: guidolivolsi@gmail.com; Corresponding author; Theoretical Knowledge Instructor.

‡Accountable Manager: Catania Flight Club.

§Head of Training; Captain Airline Pilot; Class Ratings Examiner; Flight Instructor; Class Ratings Instructor; Instrumental Rating Instructor.

¶First Officer Airline Pilot; Flight Instructor; Theoretical Knowledge Instructor.

||Chief Flying Instructor; Flight Instructor; Class Ratings Instructor; Instrumental Rating Instructor.

**Safety Manager; Chief Theoretical Knowledge Instructor; Flight Instructor; Class Ratings Instructor; Instrumental Rating Instructor; Theoretical Knowledge Instructor.

††First Officer Airline Pilot; Flight Instructor; Theoretical Knowledge Instructor.

‡‡Flight Instructor; Class Ratings Instructor; Instrumental Rating Instructor; Theoretical Knowledge Instructor.

§§Flight Instructor; Air Traffic Controller Officer.

¶¶Theoretical Knowledge Instructor; Air Traffic Controller Officer.

***President of Catania Flight Club.

†††Compliance Monitoring Manager; Flight Instructor; Class Ratings Instructor; Instrumental Rating Instructor.

‡‡‡Class Ratings Examiner; Airline Pilot; Flight Instructor; Class Ratings Instructor; Instrumental Rating Instructor.

§§§Captain Airline Pilot; Flight Instructor.

World War, the British Royal Flying Corps conducted a study aimed at clarifying the causes of many plane crashes. The results were very surprising. For every hundred pilots who died, only two had been shot down by the enemy, eight were victims of structural failure of the aircraft, while ninety deaths were attributable to errors induced by the negative balance between performance and limitations of the pilots themselves. Despite the progress of aircraft engineering and avionics, the man-machine relationship has always been the subject of speculation. The search for an appropriate know-how has not always managed to mitigate the “aeronautical fatalities”. Topics described in this paper highlight the reason for some useful needs for safe and efficient flights. Until new mutations of a molecular nature, the pilot is still a human being whose performance will have to deal with his limitations. The human factor in aviation still remains core of a heated debate.

Keywords: *Aviation, physiology.*

Riassunto

Prestazioni e limitazioni umane nell'aviazione: aspetti fisiologici e comportamentali

Il volo umano, fin dalle sue origini, è stato visto come uno scenario appropriato per tutta una serie di questioni inerenti la fisica del volo, l'architettura e la sicurezza dei aeromobili, nonché la fisiologia e la psicologia di piloti e passeggeri. Nel corso della prima guerra mondiale, la British Royal Flying Corps condusse uno studio volto a chiarire le cause di molti incidenti aerei. I risultati furono assai sorprendenti. Per ogni cento piloti deceduti, solamente due erano stati abbattuti dal nemico, otto erano vittime di cedimenti strutturali degli aeromobili, mentre novanta decessi erano riferibili ad errori indotti dal bilancio negativo fra prestazioni e limitazioni degli stessi piloti. Nonostante il progredire dell'ingegneria e dell'avionica degli aeromobili, il rapporto uomo-macchina è stato sempre oggetto di speculazioni. La ricerca di un appropriato *know-how* non sempre è riuscita ad attenuare le “fatalità aeronautiche”. Gli argomenti descritti in questo lavoro evidenziano il perché di alcune necessità utili ai fini di voli sicuri ed efficienti. Fino a nuove mutazioni di carattere molecolare, il pilota rimane pur sempre un essere umano le cui prestazioni dovranno fare i conti con i suoi limiti. Il fattore umano in aviazione rimane ancora al centro di un serrato dibattito.

Parole chiave: *Aviazione, fisiologia.*

1 Introduction

The tendency to experiment has always been one of the typical characteristics of many living beings. During evolution, the search for food and partners, needs related to biological systems, have prompted new experiences useful for survival and perpetuation of the species.

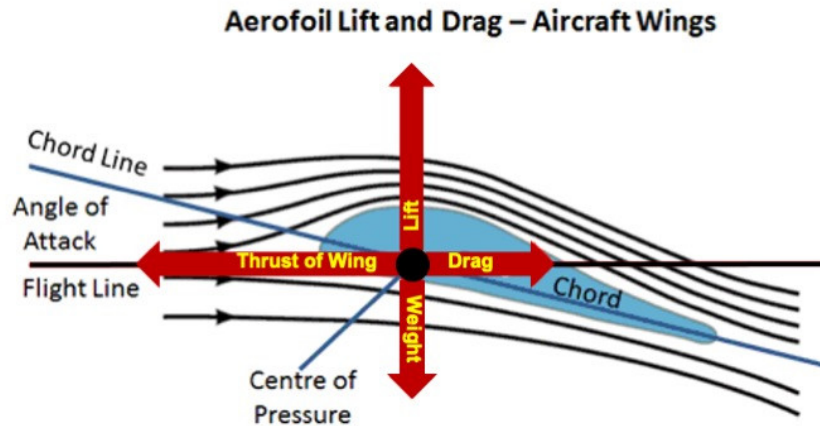

Figure 1: Aerofoil lift and drag, Eq. (1).

The search for strategies promoted by reasons of necessity followed other types of experimentations aimed at finding solutions to affirm the presence of each living being in the different social communities, its ability to interact and move, the legitimate desire to improve the social position or to be evaluated on their own merits.

In such contexts, human beings have always tempt the unusual, the new, trying to overcome barriers of physical nature, sometimes trying to force his own limits; limits imposed by its molecular architecture, by its organs and systems (Dyreson, 2020).

Flight, although not necessary for human survival, can be considered a very ancient desire, probably born from the observation of insects and birds, both organisms capable of moving in a three-dimensional space; organisms equipped with devices, wings, which allow to counteract the force of gravity.

Four centuries before Christ, Archita of Taranto, an eclectic mind between politics, philosophy and science, belonging to the second generation of the school of Pythagoras, experimented with a mechanical bird, called Archita's dove. Later, Leonardo da Vinci designed and built flying objects worthy of proper consideration. He concretized the idea of using rotating wings, such as those of a helicopter.

In physical terms, both in insects and birds with wings of adequate characteristics, and in flying objects, such as for aerodynes (aircraft with dynamic support), lift is ensured by the principle of lift. In the context of fluid dynamics, this parameter quantifies the thrust that a wing receives as a result of a pressure difference between its top and bottom, as described in the following relationship,

$$\text{Lift} = \frac{1}{2} \rho V^2 S C_p, \quad (1)$$

where ρ is the air density, V is the speed (meters/sec), S is the wing surface and C_p is the lift coefficient (Fig. 1).

As far as human flight is concerned, this type of technological evolution has always entailed and still involves a series of risks, which can be measured

in probability and severity. The desire to fly of human beings must therefore deal with the problems arising from the result of a hypothetical algebraic sum between performances and limits imposed by the architecture of their organs and systems.

The “knowing oneself”, as Socrates said, finds a lot of expression in the aeronautical field, where we cannot know our real limits until we experience conditions in which our organism is urged to operate at the limits of the physiology of its own organs and systems.

Just think about what happens during strong linear or angular accelerations or imagine conditions of spatial disorientation that a pilot can encounter during a flight in particular conditions of adverse landscape or meteorological conditions.

Therefore, the human factor continues to be the subject of in-depth studies, due to the continuous interactions with what is connected with the safety of operations.

The expression Human Factor refers to the set of operations and the ways in which man acts in his work environment, in order to increase the levels of safety in the various manoeuvres performed. In recent years, this issue has taken on ever-increasing importance, so much so that the International Civil Aviation Organization (ICAO) and all other international aviation institutions are held to carry out continuous conferences and refresher courses focused on these topics. In fact, the ICAO defines the Human Factor, in circular 227, in this way: “Human factors have as their object of study people, while they carry out their tasks, as well as their insertion into the work environment, understood in a physical and interpersonal sense, and their relationship with the work tools and procedures to be followed. The goal of this research is to pursue safety and efficiency.”

It is important to note how, in recent years, attention has shifted from a particular control of the physical conditions of the worker to more social, emotional and interaction aspects between people. This happened because, over time, the causes of accidents have changed. In fact, at the beginning of aviation, the main causes of accidents were attributed to human performance, given that aircrafts crashed due to pilot fatigue, stress, due to improper use of on-board devices.

Therefore, to solve these problems, many navigation aids were introduced and work shifts were regularized, thus succeeding in lowering the accident curve. However, during the 1970s, the curve began to rise again due to new behavioural problems. There was, in fact, a poor interaction between the pilots on board, which often led to the emergence of conflicts, to poorly understood communications, to a high hierarchy of procedures. These are factors that triggered a series of events which, in turn, resulted in a collision.

The solutions adopted were to establish personnel training programs, in order to increase the crew’s awareness of the importance of proper interaction at work, and to improve communication procedures between pilots and the various control centers.

Today, even if the accident curve is very low, efforts are being made to further reduce the occurrence of accidents and misfortunes, especially since the num-

ber of take-offs and landings that are performed every year in the world has increased considerably. This consideration has led to the deduction that one of the main causes of an accident is the loss of control of the aircraft, mainly due to a redundancy of automatisms in the cockpit, for which we are trying to improve the ergonomics of the structure.

After a careful reflection on the flight problems, it is easy to understand why captain and aircrew must be able to know and understand the functioning of their body, as well as being able to interact effectively with the environment that surrounds them. Furthermore, it is essential to be aware of the fact that the cause of an aircraft crash is never just one, as well as the responsibility for it.

This review will consider aviation performance and limitations that affect not only aircrews, but also any legal and/or natural person orbiting an aircraft. We refer to manufacturing companies, engineers, technicians and validators of the various processes relating to production, checks during production, putting on line, ordinary and extraordinary maintenance required by manufacturers and regulations. Later, space will be given to topics concerning the classic conventional flight, (flight on a propeller aircraft equipped with an internal combustion engine), unless there are some references under different conditions for illustrative reasons.

As for the pilot, the holder of a PPL A (Private Pilot License -A) type flight license will be considered, which allows to operate on aircraft for non-commercial purposes, according to the visual flight rules (VFR), with extension of privileges to VFR night flight; in other contexts, an airline pilot, with an ATPL license (Airline Transport Pilot License).

2 Legislation and References in the aeronautical field

After a very onerous and delicate drafting work, on 7 December 1944 in Chicago, a Convention was signed which, after the deposition of the ratifications by the States, became effective on 4 April 1947 with the aim of:

- Establish privileges and limitations for all Contracting States;
- Take care of the international adoption of Standards and Recommended Practices;
- Recommend the installation of navigation aids;
- Facilitate air travel.

Thus, [ICAO](#), above mentioned, was born, with the task of developing and distributing various types of publications such as Technical Annexes, Documents, Manuals and essential notes for the purposes of air navigation. Among these publications, of particular interest are 19 Technical Annexes or Annexes (Table 1), each dedicated to a relevant topic of international Civil Aviation. Each Annex contains Technical Standards and Recommended Practices of a technical, economic and regulatory nature.

Annex 1	Personnel Licensing
Annex 2	Rules of the Air
Annex 3	Meteorological Service for International Air Navigation
Annex 4	Aeronautical Charts
Annex 5	Units of Measurement to be Used in Air and Ground Operations
Annex 6	Operation of Aircraft
Annex 7	Aircraft Nationality and Registration Marks
Annex 8	Airworthiness of Aircraft
Annex 9	Facilitation
Annex 10	Aeronautical Telecommunications
Annex 11	Air Traffic Services
Annex 12	Search and Rescue
Annex 13	Aircraft Accident and Incident Investigation
Annex 14	Aerodromes
Annex 15	Aeronautical Information Services
Annex 16	Environmental Protection
Annex 17	Security
Annex 18	The Safe Transport of Dangerous Goods by Air
Annex 19	Safety Management System

Table 1: ICAO Annexes.

In EU, has been established the European Aviation Safety Agency (EASA), which ensures safety and environmental protection of air transport.

EASA harmonises regulations and certifications, develops the EU single aviation market, develops technical standards in the aviation sector, certifies aircraft and components, approves organizations that design, manufacture and maintain aeronautical products, carries out checks and provides support to EU countries, promotes European and global safety standards with international stakeholders in order to improve safety in Europe.

Member countries have subsequently implemented these regulations, including them in the architecture of their administrative and control activities of airports and air traffic. In Italy, the National Civil Aviation Authority (ENAC) and the National Flight Safety Agency (ANSV) were created, both regulatory bodies, which ensure efficient and safe flights within the entire national airspace.

Aircrew and ground staff operating in airports are required to acquire the contents of the ICAO Annexes, the EASA, ENAC standards and ANSV respectively for the parts relating to their own competences and areas of application.

In the rest of this review we will consider some of the aspects of the general aviation world, such as pilot training, standard controls related to an air mission, routines and particular operating conditions that his body must endure during certain activities and manoeuvres during the flight; everything will have to deal with his physiology and behaviours. A final step will concern risk management.



Figure 2: P2002 JF (Aeronautical Industries TECNAM S.p.A., Capua, Italy).

3 Pilots training and solicitation of organs and systems

The progress of a pilot's training depends on many variables. They concern analysis of information, level of attention and vigilance, memorization processes, the technique of learning, the awareness of the situation, the management of errors (avoidance and management), cooperation and communication, personality, attitude and behaviour, self-discipline, amount of work, state of alertness, stress and fatigue (Socha *et al.*, 2020).

As he proceeds, he begins to put in place mechanisms such as acquisition, planning, implementation, verification, correction and improvement of his own performance, as well as anticipation processes (feedforward mechanisms), fundamental for the construction of a probable scenario. In other words, he begins a sort of adventure that will see him engaged, together with his flight instructor, to play a game whose progress and final outcome will depend on his level of will and desire to arrive. This, in order not to disappoint himself, as well as the instructor.

The inevitable stress of the nervous system, which had already begun at the time of his choice to attend a flight training course, continues at the moment of physical contact with one of the school aircraft (Figs. 2, 3).

If the scenario is appealing at first glance, it will soon be necessary to deal with the content management of this scenario.

As can be seen in Fig. 2, a school aircraft is usually equipped with a series of essential tools and devices for its efficient and safe conduct on the ground and in flight.

The need for some instruments during flight arises from the fact that the pilot, due to the limits imposed by his biological architecture, cannot accurately determine some fundamental parameters for air navigation (Chialastri, 2015). Fig. 4 expands the area on the left of Fig. 3. It shows some tools necessary for



Figure 3: On-board devices and avionics inside the cockpit of the P2002 JF (Aeronautical Industries TECNAM S.p.A., Capua, Italy).

basic navigation. In particular, an artificial horizon (top, centre)¹, an anemometer (top left)², an altimeter (top right)³ and a directional gyro⁴ (Fig. 4).

There is also a turn coordinator (bottom left)⁵ and a vertical speed indicator (bottom right)⁶. Before leaving this part of the dashboard, it is important to consider the concept of human-machine interaction.

Until the advent of the Glass-cockpit, whose main advantage is to replace a fair amount of analog indicators with a few monitors on which to show (when necessary) the parameters required for that particular flight phase, improving the attention of the pilots, for a long time they have used and still use an instrument panel structured according to the T model.

As can be seen in Fig. 4, the main reference tool is the artificial horizon with which the aircraft attitude data are obtained. On its left the instrument relating

¹Directional gyro instrument that indicates the attitude of the aircraft in the flight phases.

²Capsule instrument indicating speed (expressed in nautical miles - knots).

³Capsule instrument that indicates the flight altitude (in Meters and others in Feet).

⁴Instrument that indicates the direction in which the aircraft is flying, with respect to the North.

⁵To understand the use of this tool, it is necessary to know that every time an aircraft turns, in addition to tilting the wings, a sort of drift effect is created. When the aircraft turns, for example to the left, the centrifugal force can move the aircraft to the right creating the drift. In this case the sphere will go to the right, or towards the outside. If, on the other hand, always in the turn to the left, you observe the sphere going to the left, or towards the inside, you will have a slide. The pilot must always keep the sphere in the center, moving the rudder through a pedal, in order to maintain the right balance between the forces during the turn.

⁶Capsule instrument that indicates the sync rate (vertical component of the climb/descent speed of the aircraft), expressed in units of feet/min, such as to provide the pilot with information on the vertical motion (altitude variation over time) of the aircraft.



Figure 4: Detail of the on-board instrumentation of a P2002 JF, Tecnam. Note the arrangement of the essential tools described above. In the centre the artificial horizon, on the left the anemometer, on the right the altimeter, at the bottom the directional gyro.

to the given speed, on the right the one relating to the given altitude. The T is completed by the fourth instrument which provides the given navigation. The left part of the dashboard in Fig. 2 shows at the top two other instruments used for radio navigation, the Very High Frequency Omnidirectional Range (VOR), and the Automatic Direction Finder (ADF).

The central part of the dashboard contains the radio communications equipment (two), the transponder and the ADF management device.

The right side of the dashboard (Fig. 5) contains various instruments for reading data relating to propeller revolutions per minute, engine temperature and cylinder head temperature, external temperature, engine oil pressure, fuel pressure, fuel levels. in the wing tanks, voltmeter, ammeter. Finally, there is an instrument for reading the degrees of inclination of the flaps and a chronometer.

Being a school aircraft, the dashboard is completed with some dual controls (engine throttles and control bars for ailerons and horizontal tail plane), as well as light switches (stroboscopic, navigation, taxiing, landing). Finally, there is a lever for managing the flaps, the hot air in the cabin, the hot air that acts on the carburettor and for managing the air-fuel mixture. Finally, a pedal unit ensures the control of the moving part of the centreboard, the rudder.

The description of the above devices (instruments, levers, switches, buttons), without going into further details, provides the conditions for framing some of the activities that student pilot learns to perform on the ground and, sub-

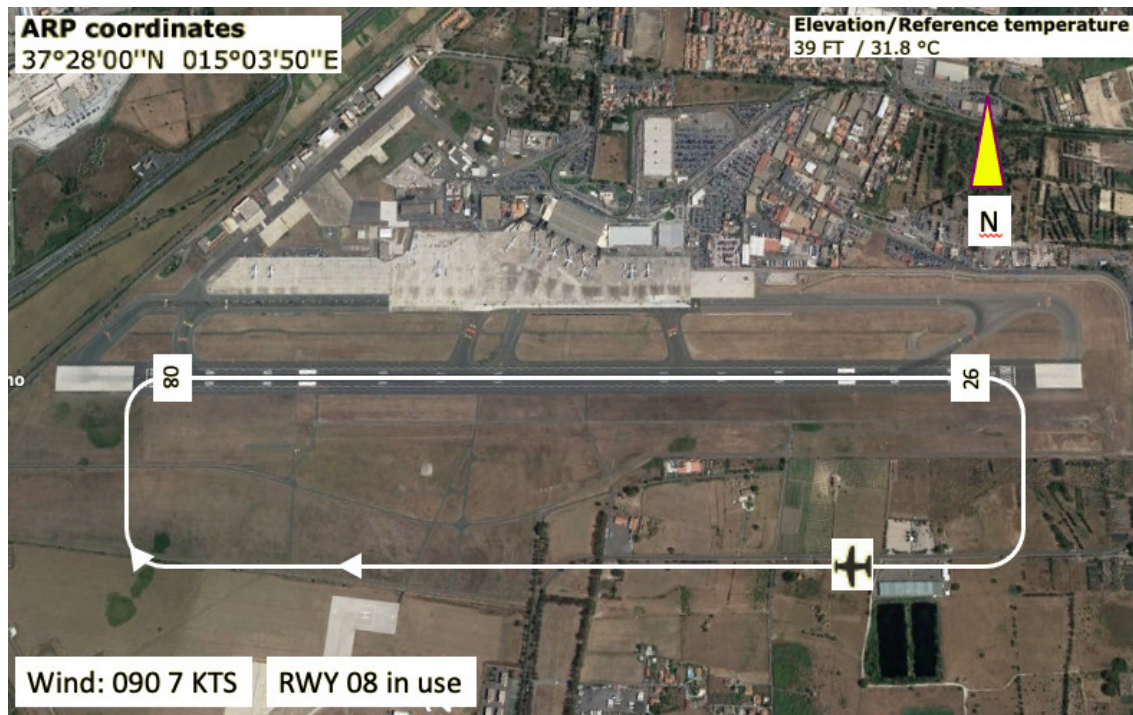

Figure 6: Schematic representation of the traffic circuit at Catania International Airport-I. Wind and runway in use are hypothetical.

the instructor to authorize his pupil the traffic circuit does not arise from purely mathematical calculations, but from the maturation of certain convictions deriving from a very careful study: psychology of the pupil, state of mind, maturation achieved in the field of knowledge and safety of procedures for conducting that formative moment.

For his part, the student pilot will have already undertaken to develop in his instructor the belief that time has come, through a whole series of evidence. The orderly management of routines, critical situations and emergencies without panic, of the return to normality that must be experienced not as an achievement but as the term of routines that are likely to occur during the various phases of the flight.

So, the student pilot will continue his theoretical-practical training which will lead him, on the one hand, to pass the theoretical exams and, on the other hand, to pass the planned piloting test. This second moment will take place when his instructor will have ascertained his maturity and the ability to deal with all the manoeuvres foreseen by the training plan with dexterity and safety.

In other words and in a more specific language in the aeronautical field, the student will be “recommended” to take the exam with an examiner indicated by ENAC; examination that will lead to the acquisition of the PPL (A), in accordance with the provisions of Annex 1 of the ICAO–Personnel Licensing.

In terms of performance and limitations, error, safety and man-machine relationship, the human factor will have already played its part in training moments.



Figure 7: On the left, Diamond DA 40 180 (Diamond Aircraft Industries GMBH), on the right the cockpit. It is a single-engine model, equipped with a Textron Lycoming injection, variable pitch propeller and fixed landing gear.

4 The need for aids capable of relieving the pilot's workload

The birth of a checklist and actions to be carried out in the various moments of conducting a flight dates back to an event that occurred on October 3, 1935. During a flight test scheduled by the United States Army Air Corps for the adoption of a new bomber of the Boeing, it happened that the aircraft stalled a few minutes after take-off. Appropriate investigations revealed that human error was decisive in causing the accident.

The conduct of the new aircraft involved the pilot monitoring the four engines via hydraulic controls, a retractable landing gear, newly designed flaps, trim tabs and numerous other flight systems. Concentrating on managing these devices, he had forgotten to deactivate the "Gust Lock", a mechanism responsible for locking the altitude and direction rudders, normally active in the parking phase.

Therefore, a new problem arose. The aircraft in question, later called B-17, was too complex to be managed by relying solely on the pilot's memory. Hence, the first checklist.

It represents an indispensable tool for the management of an aircraft in all its phases of use, capable of eliminating memory lapses and attention deficits, especially if complex operations are carried out, *i.e.* series of implementation sequences foreseen in a short time.

By way of example, we will consider the short (simplified) checklist of the DA40-180 (Fig. 7), an aircraft built in Austria at the Diamond Industries, taken from the more complete (extended) one described in the aircraft flight manual.

A simplified checklist (Table 2) presents some main sections that are divided, in turn, into a whole series of calls, called checks, which can be followed by actions.

Below is the list of checks and actions to be carried out for each section and information provided by the pilot to passengers. The pilot, after acquiring the weather information relating to the scheduled flight plan, begins a whole series of detailed checks as provided in the above sections. His attention is already

1. Cabin Preliminary Check
2. External Walk-Around
3. Before Starting Engine
4. Engine Fire On The Ground
5. Engine Starting Cold Condition
6. Engine Starting Warm Condition
7. When Engine Fires
8. Before Taxing
9. Taxiing
10. Engine Run-Up Before Take-Off
11. Take-Off
12. Climb
13. Cruise
14. Descent
15. Landing Approach
16. Go-Around
17. After Landing
18. Engine Shot-Down
19. Post-Flight Inspection

Table 2: DA40-180- Sections of the simplified checklist.

maximum; he has decided that he will fly the aircraft.

4.1 Cabin Preliminary Check

1. MET.NAV.MASS & CG: Completed
2. A/C DOC: Complete and Up-to-date
3. IGNITION KEY: Pulled out
4. EMERGENCY EQUIPMENT
5. FRONT CANOPY & REAR DOOR: Check
6. ALL ELECTRICAL EQUIPMENT: Off
7. CIRCUIT BREAKERS: Set in
8. ENGINE CONTROL LEVERS: Check
9. THROTTLE: Idle
10. MIXTURE CONTROL LEVER: Lean
11. RPM LEVER: High RPM
12. MASTER SWITCH (BAT): On
13. ANNUNCIATOR PANEL: Check
14. FUEL QUANTITY: Check

15. POSITION & STROBE LIGHT: Check
16. MASTER SWITCH (BAT): Off
17. CHECK LOOSE ITEMS: Complete
18. FLIGHT CONTROLS & TRIM: Free
19. AGGAGE: Stowed and secure
20. EMG AXE: Stowed and secure
21. EMG HAMMER: Stowed & secure

4.2 External Walk-Around

1. Left hand fuel filler cap: check visually for desired fuel level and secure.
2. Remove protection cap and check pitot mounted on left strut is unobstructed, do not blow inside vents, place protection cap inside aircraft.
3. Left side leading edge and wing skin: visual inspection
4. Left aileron: visual inspection
5. Left flap and hinges: visual inspection
6. Left main landing gear; check inflation, tire condition, alignment, fuselage skin condition.
7. Horizontal tail and tab: visual inspection.
8. Vertical tail and rudder: visual inspection.
9. Right side main landing gear; check inflation 14 psi (1.0 bar), tire condition, alignment, fuselage skin condition.
10. Right flap and hinges: visual inspection.
11. Right aileron: visual inspection.
12. Right leading edge and wing skin: visual inspection.
13. Check stall
14. Right side fuel filler cap.
15. Right side static port: check for obstructions, do not blow inside vents (read note).
16. Nose wheel strut and tire: check inflation, tire condition and condition of rubber shock absorber discs.
17. Propeller.
18. Check amount of lubricant.

4.3 Passenger Briefing

The pilot informs passengers about weather conditions, contents of flight mission, places that will be flown over, management of any critical moments.

4.4 Engine Fire On Ground

1. FUEL TANK SELECTOR: Off
2. CABIN HEAT: Off
3. BRAKES: Apply
4. THROTTLE: Max PWR
5. MASTER SWITCH (ALT/BAT): Off
6. IGNITION SWITCH: Off
7. CANOPY: Open
8. AIRPLANE: Evacuate immediately

The above sequence indicates a whole series of actions that pilot will have to carry out, in sequence, in the event of an engine fire, in conditions of aircraft on ground. The pilot is required to memorize this sequence, in order to manage the safety of the aircraft and its abandonment in the shortest possible time.

4.5 Before Starting Engine (Cold Engine)

1. PRE-FLIGHT INSPECTION: Complete
2. FUEL DIPSTICK: Check on Board
3. RUDDER PEDALS: Adjusted
4. PASSENGER: Instructed
5. SAFETY HARNESSSES: All on and fastened
6. BAGGAGE: Check, secured
7. REAR DOOR: Closed and locked
8. FRONT CANOPY: Closed
9. PARKING BRAKE: Set
10. FLIGHT CONTROLS: Free
11. TRIM WHEEL: T/O
12. THROTTLE: Idle
13. RPM LEVERS: High RPM
14. MIXTURE CONTROL LEVER: Lean
15. FRICTION DEVICE, THROTTLE QUADRANT: Adjusted
16. ALTERNATE AIR: Closed
17. AVIONICS MASTER SWITCH: Off
18. ESSENTIAL BUS SWITCH: Off
19. MASTER SWITCH (BAT): On
20. ANNUNCIATOR PANEL: Test
21. FUEL TANK SELECTOR: On full tank

4.6 Engine Starting

4.6.1 Cold Engine

1. STROBE LIGHT (ACL): On
2. MIXTURE CONTROL LEVER: Rich
3. THROTTLE: 1 cm FWD from idle
4. ELECTRICAL FUEL PUMP: On, note pump noise, 3 second then off
5. MIXTURE CONTROL LEVER: middle
6. THROTTLE: 1 cm FWD from idle
7. IGNITION SWITCH: Start

When Engine Fires

1. MIXTURE CONTROL LEVER: Rapidly move to rich
2. OIL PRESSURE: Green sector within 15 second
3. ELECTRICAL FUEL PUMP: Check Off
4. MASTER SWITCH (ALT): On
5. AMMETER: Check
6. FUEL PRESSURE: Check (14-35 psi)
7. ANNUNCIATOR PANEL: Check

4.6.2 Warm Engine

1. STROBE LIGHT: On
2. MIXTURE CONTROL LEVER: Rich
3. THROTTLE: 1 cm FWD from idle
4. MIXTURE CONTROL LEVER: middle
5. THROTTLE: 1 cm FWD from idle
6. IGNITION SWITCH: Start

When Engine Fires

1. MIXTURE CONTROL LEVER: Rapidly move to rich
2. OIL PRESSURE: Green sector within 15 second
3. ELECTRICAL FUEL PUMP: Check Off
4. MASTER SWITCH (ALT): On
5. AMMETER: Check
6. FUEL PRESSURE: Check (14-35 psi)
7. ANNUNCIATOR PANEL: Check

Before taxiing

1. AVIONIC MASTER SWITCH: On
2. ELECTRICAL EQUIPMENT: On as req
3. FLAPS: UP-T/O-LDG-T/O check
4. FLIGHT INSTRUMENT AND AVIONICS: Set, Test function, as req
5. FLOOD LIGHT: On, test function, as req
6. AMMETER: Check, if req increase RPM
7. FUEL TANK SELECTOR: Change tank, confirm that the engine also run on the other tank (at least 1m at 1500 RPM)
8. PITOT HEATING: On, test function, ammeter must show rise, off
9. STROBE LIGHT: Check on
10. POS, LAND, TAXI LIGHTS: On, as req
11. THROTTLE: Idle (check 600-800 RPM)

Taxiing

1. PARKING BRAKE: Release
2. BRAKES: Test on moving off
3. FLIGHT INSTRUMENT AND AVIONICS: Check for correct indications

Engine Run-Up

1. PARKING BRAKE: Set
2. SAFETY HARNESSSES: On and fastened
3. REAR DOOR: Closed and locked
4. FRONT CANOPY: Closed and locked
5. DOORS WARNING LIGHTS: Check off
6. FUEL TANK SELECTOR: Fullest tank
7. ENGINE INSTRUMENT: In green arc
8. CIRCUIT BREAKERS: Pressed in
9. FUEL PRESSURE: Check (14-35 psi)
10. THROTTLE: 2000 RPM
11. RPM LEVER: Pull back until a drop of 250 to 500 RPM is reached – High RPM 3 times
12. MAGNETO CHECK: L – both – R - both
Max RPM drop ... 175 RPM

Max difference ... 50 RPM

13. CIRCUIT BREAKERS: Check in
14. VOLTEMETER: Check in green range
15. THROTTLE: Idle
16. PARKING BRAKE: As required

Before Take-Off

1. PARKING BRAKE: Set
2. ELECTRICAL FUEL PUMP: On
3. MIXTURE CONTROL LEVER: Rich
4. FLAPS: Check T/O
5. TRIM: Check T/O
6. FLIGHT CONTROLS: Free movement
7. ALTERNATE AIR: Check closed
8. LANDING LIGHT: On as required
9. PITOT HEATING: On as required
10. TAKE-OFF BRIEFING: Perform
11. PARKING BRAKE: Release

Take-Off

1. TRANSPONDER: On/alt - set as req.
2. RPM LEVER: Check high RPM
3. THROTTLE: Max PWR (not abruptly)
4. ELEVATOR: Neutral
5. RUDDER: Maintain direction
6. NOSE WHEEL LIFT-OFF: Vr 59 KIAS
7. AIRSPEED:
 - 67 KIAS (1200 KG)
 - 66 KIAS (1150 KG)
 - 60 KIAS (> 1000 KG)
8. ABOVE SAFE HEIGHT
9. RPM LEVER: 2400 RPM
10. ELECTRICAL FUEL PUMP: Off
11. LANDING LIGHT: Off

Climb**PROCEDURE FOR BEST RATE**

1. FLAPS: T/O
2. AIRSPEED:
 - 67 KIAS (1200 KG)
 - 66 KIAS (1150 KG)
 - 60 KIAS (1000 KG)
 - 54 KIAS (850 KG)
3. RPM LEVER: 2400 RPM
4. THROTTLE: Max PWR
5. MIXTURE CONTROL LEVER: Rich, above 5000 ft hold EGT constant
6. ENG. INSTRUMENTS: In green arc
7. TRIM: As required
8. ELE. FUEL PUMP: On at high alt.

CRUISE CLIMB

1. FLAPS: Up
2. AIRSPEED:
 - 76 KIAS (1200 KG)
 - 73 KIAS (1150 KG)
 - 68 KIAS (1000 KG)
 - 60 KIAS (850 KG)
3. RPM LEVER: 2400 RPM
4. THROTTLE: Max PWR
5. MIXTURE CONTROL LEVER: Rich, above 5000 ft hold EGT constant
6. ENG. INSTRUMENTS: In green arc
7. TRIM: As required
8. ELE. FUEL PUMP: On at high alt.

Cruise

1. FLAPS: Up
2. THROTTLE: Set (performance table)
3. RPM LEVER: 1800-2400 RPM

4. MIXTURE CONTROL LEVER: Set (4a.310 – mixture adjustment)
5. TRIM: As required
6. FUEL TANK SELECTOR: As required (max difference 8 US GAL)
7. ELECTRICAL FUEL PUMP: On at high alt.

Descent

1. MIXTURE CONTROL LEVER: Adjust as required for the altitude, operate slowly
2. RPM LEVER: 1800-2400 RPM
3. THROTTLE: As required
4. ELE. FUEL PUMP: On at high alt.

Landing

Approach

1. FUEL TANK SELECTOR: Fullest tank
2. ELECTRICAL FUEL PUMP: On
3. SAFETY HARNESSSES: Fastened
4. AIRSPEED: 108 KIAS Flaps operation
5. FLAPS: T/O
6. TRIM: As required
7. LANDING LIGHT: As required

Before Landing

1. MIXTURE CONTROL LEVER: Rich
2. RPM LEVER: High RPM
3. THROTTLE: As required
4. AIRSPEED: 91 KIAS Flaps operation
5. FLAP: LDG
6. APPROACH SPEED:
 - 73 KIAS(1200 KG)
 - 71 KIAS (1150 KG)
 - 67 KIAS (1092 KG)
 - 63 KIAS (1000 KG)
 - 58 KIAS (850 KG)

Go-Around

1. TRHOTTLE: Max PWR
2. AIRSPEED:
 - 67 KIAS (1200 KG)
 - 66 KIAS (1150 KG)
 - 60 KIAS (1000 KG)
 - 54 KIAS (850 KG)
3. FLAPS: T/O
4. RPM LEVER: 2400 RPM
 - Above Safe Height
5. AIRSPEED:
 - 76 KIAS (1200 KG)
 - 73 KIAS (1150 KG)
 - 68 KIAS (1000 KG)
 - 60 KIAS (850 KG)
6. FLAP: Up
7. ELECTRICAL FUEL PUMP: Off

After Landing

1. THROTTLE: Idle
2. BRAKES: As required
3. ELECTRICAL FUEL PUMP: Off
4. TRANSPONDER: Off/STBY
5. PITOT HEATING: Off
6. AVIONICS: As required
7. LIGHTS: As required
8. FLAPS: Up

Engine Shut Down

1. PARKING BRAKE: Set
2. ENGINE INSTRUMENT: Check
3. AVIONIC MASTER SWITCH: Off
4. ALL ELECTRICAL EQUIPMENT: Off
5. THROTTLE: 1000 RPM

6. IGNITION CHECK: Off until RPM drops noticeably, then immediately both again
7. MIXTURE CONTROL LEVER: Lean - shut engine off
8. IGNITION SWITCH: Off
9. MASTER SWITCH (ATL/BAT): Off

Post-Flight Inspection

1. IGNITION SWITCH: Off, remove key
2. MASTER SWITCH (BAT): On
3. AVIONIC MASTER SWITCH: On
4. ELT: Check activated listen on 121.5
5. AVIONIC MASTER SWITCH: Off
6. MASTER SWITCH (BAT): Off
7. PARKING BRAKE: Release, use chocks
8. AIRPLANE: Moor

Summarizing and quantifying all the phases and related procedures of a flight carried out with this aircraft, from the moment of its taking over, by affixing the signature to the aircraft technical log⁸, until its return, the pilot will have carried out over two hundred checks and actions. To these must be added those relating to the management of the engine and the propeller pitch as a function of the flight altitude and the choice between a flight in power or economy. Apart from the controls on the ground, all carried out on a three-dimensional environment in which a possible variable is almost always present, that is the wind⁹.

In conclusion, if on the one hand the simplified checklist may appear to the pilot as a repetitive moment, almost reductive in relation to his own "proficiency", on the other hand it represents an essential, but not unique, tool for the safe and efficient conduct of the flight.

Indeed, airline pilots have different control routines and activities that they rely on their memory skills, however many activities refer to checklists and actions provided by the manufacturer and the airline according to predetermined standards.

⁸The on-board technical log is a register, which accompanies each aircraft, in which the hangar staff indicates hours flown, hours remaining before scheduled maintenance, quantity of engine oil present, fuel. The pilot, on his part, notes take-off and arrival airports, flight time, number of landings made and any notes relating to failures/malfunctions found. In the latter case, the aircraft loses its airworthiness, until the technical conditions provided for in the flight manual are restored.

⁹The wind can be defined as a movement of atmospheric air masses that occurs horizontally, from a high pressure area to a low pressure area. Where the displacement occurs vertically, we speak of convective movement or vertical current.

		Risk severity			
		Very Serious	Serious	Minor	Irrelevant
Risk probability	Very High	Unacceptable	Unacceptable	Reviewable	Reviewable
	High	Unacceptable	Unacceptable	Reviewable	Improvable
	Possible	Unacceptable	Reviewable	Improvable	Acceptable
	Remote	Reviewable	Improvable	Improvable	Acceptable
	Irrelevant	Improvable	Improvable	Improvable	Acceptable

Table 3: Risk assessment.

5 Checklist and human factor

Human performance represents the human contribution to the performance of the “system” and refers to the way people do their jobs. In aviation, and not only in this area, people can be both the source of a risk and the component involved in its identification and management.

The quantification of risk (R) derives from the product of probability (p) and severity (g),

$$R = p \cdot g. \quad (2)$$

Here it is worth defining the risk matrices (Table 3) that quantify their probability and severity.

If a risk is predictable, identifiable and quantifiable, it will have a good chance of being managed, limiting its consequences. For this reason, the Italian legislation on the subject requires the preparation of a risk assessment document. This is a series of considerations that represent the mapping of health and safety risks in a company, required in electronic or paper format by the Consolidated Law on safety at work (Legislative Decree 81/2008), where it is dealt with in articles 17 and 28. All legal entities operating in the aeronautical world are also required to draft this document. This is the responsibility of manufacturing companies, management and control bodies, as well as operational structures.

When the pilot takes charge of the aircraft, he becomes the captain/manager. For this reason, it will be up to him to make a whole series of assessments relating to the choices in terms of personal, crew and passengers and aircraft safety. The risk assessment will not be *una tantum*, but systematic, in order to guide its decisions for a good balance between probability and severity.

As previously mentioned, a checklist is also created with the aim of reducing the risks that a pilot can run due to any omissions or malfunctions of parts of the aircraft. As such, it represents a sort of reference for the purposes of the safe management of the aircraft during all phases of the flight. Thus, the controls and actions described in it can be compared to the links of a chain, the total strength of which will depend on the strength of the individual links. The examples given below will serve to better clarify how a link in this chain can change its status, if some controls and actions of the pilot fail to have the correct sequential order.

Fuel tanks. The ignition of the aircraft engine, referred to in the checklist, requires that this procedure takes place by placing the fuel tank selector on the fullest one; therefore, before taxiing, in order to check the operation of the other tank and the relative power supply circuit of the engine, the pilot places the fuel selector on the other tank, at least for one minute with propeller revolutions equal to 1500 Revolutions per Minute (RPM).

He will then reposition the fuel selector to the fullest tank. In this regard, the procedures provide that the take-off takes place, using the fullest tank. Failing to check the operation of one of the two tanks and the related circuit weakens one of the links in the engine management chain.

In fact, since at very specific time intervals, during the flight the pilot is required to change the fuel tank of the engine, if he did not do so during the ground control phase, he will never know if both tanks and electro-hydraulic circuits are operational. He will also not be able to use one of the two tanks because it is not operational. The flight and its safety will begin to be compromised. The pilot will be alerted because he has half the fuel planned for that particular route, then he will consider whether to return to the airport from which he took off or to head to an alternate airport¹⁰.

Engine run-up. The checks provided in the DA40-180 checklist require the pilot to test the engine. To do this, he will make sure that the engine instruments are in green arc (normal operation), that the fuel pressure is between 14 and 35 psi. Then he puts the throttle at 2000 RPM and after further checks, tests the operation of both the left and right magnets. The exclusion of each of the two magnets must produce a fall in the RPM value that does not exceed the value of 175 and that the maximum difference between the two magnets is 50 RPM. Also in this case, failure to test the magnets will not allow the rider to highlight any anomalies in the functioning of these circuits.

The Take-Off. A safe take-off requires among the checks that the flaps are positioned in Take-Off (T/O), *i.e.* that they have an inclination of 15°, that the

¹⁰According to the ICAO definition, the alternate airport is an airport to which an aircraft can proceed when it becomes impossible or inadvisable to proceed to or land at the intended landing airport. Alternate airports include the following:

- Alternate take-off (alternate take-off). Alternate airport in which an aircraft can land should it become necessary immediately after take-off and it is not possible to use the departure airport.
- En-route alternate. Airport on which an aircraft may be able to land after encountering abnormal or emergency conditions en route.
- Alternate en-route alternate (ETOPS en-route alternate). Suitable and appropriate alternate aerodrome on which an aircraft may be able to land after an engine shutdown or after encountering abnormal or emergency en-route conditions during an ETOPS flight.
- Destination alternate (Destination alternate). Alternate airport to which an aircraft must/can proceed if it becomes impossible or inadvisable to land at the intended landing airport. The departure airport can also be an alternate airport.

trim is positioned on T/O and more.

It will be understood that not inserting the flaps during take-off will result in a decrease in the lift of the wing at low speeds. In this condition, the wind (of intensity x and y direction) during take-off can have even marked effects. On the other hand, failure to insert the trim with the parameters set out in the aircraft flight manual will weigh down the controls, concentrating the pilot on them and distracting him from the controls and activities foreseen in this phase of the flight. As can be easily deduced, these two rings will be weakened, acting on the increased risk of a maneuver that is no longer safe.

Approaching and Landing. Both of these procedures have controls and activities of variable criticality. We will consider the approach speed and the insertion of the flaps, partial in the approach phase (T/O) and then extended in the landing phase (LDG). A correct approach speed (108 KIAS), together with a correct angle of descent will create the conditions for optimal contact with the runway.

It goes without saying that, in standard wind conditions in intensity and direction, the extended flaps generate greater lift, necessary in the final phase of landing. The exact setting of these two parameters will avoid weakening of the links in the chain referable to them. It should also be noted that the final speed will also take into account the total weight of the aircraft, in accordance with the provisions of the flight manual in the "Weight and Balance" section.

Overall, the DA40-180 checklist can be considered as a chain consisting of several sections (19 main blocks of links) which, in turn, are divided into secondary blocks. The strength of each ring will be expressed by the algebraic sum between the components of the system and those attributable to the pilot.

In summary, the pilot uses the checklist that allows him to fly the aircraft with good safety; he is also included in a system which, through a team of experts, makes his aircraft efficient and, within certain limits, safe. Finally, the management of the system is responsible for coordinating all those activities that make the means usable. Therefore, there are continuous interactions between humans and things in which the exchange of information should help to avoid errors or, in the event that these occur, know how to manage them. In conclusion, the error can occur, but a good social culture, as well as technical and scientific, should improve the quality and everyday life of behaviours in order to avoid accidents. On this context, the literature accidents is quite substantial and proposes several theories. On the subject, Army Corps General [Valente](#) (Italian Air Force) (2008) has proposed a study concerning flight safety and the cause of accidents, indicating how the accident is the last link in a series of interlinked events. Hence the task of Flight Security to "break the chain of events" leading to the accident. In fact, the Domino Theory says that if you push the first piece of a series, all the others fall (or happen) in sequence (and this sequence proceeds inexorably until the accident). But if you remove a piece, that is a cause (Unsafe Act Or Condition), the sequence is interrupted and the accident is avoided. At this point it is important to point out a fundamental concept: "Accidents, in general, have

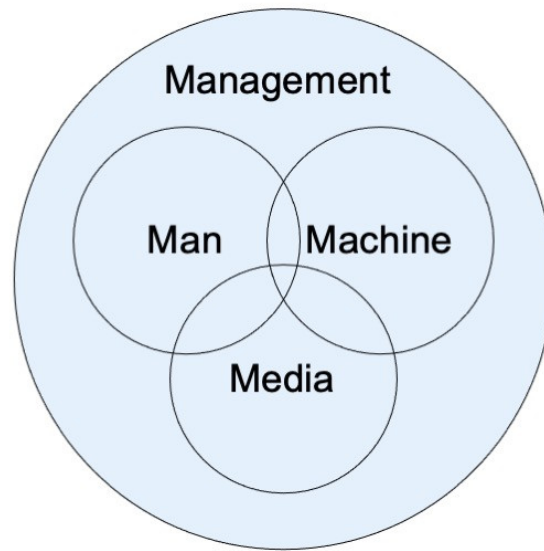

Figure 8: Multiple Causation Theory.

more than one cause” (Theory of Multiple Causes); there are very few accidents with a single cause. Therefore, the chains/sequences of events can be more than one and it is not certain that removing a cause will not lead to an accident. This concept helps us to say that there are no primary, main or most important causes, but that every cause is infinitely important for the accident and therefore none should be ignored or not investigated and corrected (Multiple Causation Theory).

[Hosseinian and Torghabeh \(2012\)](#) published a review concerning “Major Theories of construction accident causation models”. The authors concluded that *accidents and incidents in construction workplaces are unplanned and unwanted occurrences involving movement of persons, objects or materials which may result in injury, damage or loss to property or people. The majority of accidents happen when employees disregard safety rules (Unsafe acts) and management ignore the presence of unsafe conditions. Therefore unsafe acts and unsafe conditions are the immediate (direct) causes of accidents. On the other hand, physical and mental condition of the person as well as environmental forces and supervisory safety performance are the contributory (indirect) causes of accidents. Accidents are determined to follow a pattern; accidents causation theories and models provide explanations of why accidents and incidents happen.*

All the construction accident causation theories and models developed have considerably increased the understanding of accidents and how they happen. They have stimulated a strong and powerful emphasis on the role of human error which has resulted into a reasonable place for training and education of workers in order to develop competencies and safety awareness. However there is a fundamental dilemma which is the different interpretations of risk, safety and the extent of risk which needs to be reduced to be acceptable. People are likely to believe that once an action is executed in response to a hazard, the situation is safe or safe enough. The weakness of the accident causation theories is that they do not offer extensive strategic guidelines for managers and supervisors

for reducing risks at construction workplaces.

Moreover, these theories have implied the inappropriate perception that accidents in workplaces can be prevented in case human errors are eliminated. Since risk is beyond the human intervention, not all accidents are preventable. Strategies require to be revised in a manner to manage the risk and workers need to be watchful of it. A great number of accidents can be prevented if the safety management system reflects both natural degradation and these intrinsic threats. The initial step in developing such system is preparing a model which shows the interaction between the accident likelihood and organizational tasks and activities in the presence of these hazards (Fig. 8).

6 The Dryden Accident. A sample of Multiple Causation

The investigation below is the excerpt ([Dryden](#)) of the chapter of a book ([Petti et al., 2000](#)) which summarizes an aircraft crash and its investigation by a commission chaired by a senior magistrate, Judge [Moshansky \(1992\)](#).

This investigation, we report below, represented for Canada a significant turning point for the subsequent reorganization of civil aviation, moreover in a country already at an advanced level compared to the vast majority of industrialized countries.

Furthermore, the investigative criterion applied was based on the state of the most advanced knowledge in the field of human factor, of theories of error dynamics and of the influence of the organizational fabric on human behavior.

The complex answer is a message to everyone with a role in aviation - regulatory, managerial, organizational and operational.

Captain George Morwood and First Officer Keith Mills were on shift for two return flights, departing from Winnipeg (Manitoba) to Thunder Bay (Ontario); the first flight included an intermediate stopover at Dryden provincial airport both on the outward and return journeys. The second flight was direct: Winnipeg, Thunder Bay and back. Six routes in total.

The aircraft was a Fokker 28, a short-range twinjet.

Air Ontario, a regional airline, was headquartered in London, 170km south of Toronto, and operated 'feeder' connections to Air Canada.

The crew arrived in Winnipeg at 6.40am (Central Standard Time) for departure at 7.25am. According to the schedule they should have returned to Winnipeg, for the second time, at 3.30 in the afternoon.

The weather forecasts were not encouraging. Conditions were deteriorating, with lower cloud cover and precipitation of freezing rain mixed with snow.

Since diversion was possible, due to the high passenger load, the plane would have to make an additional refueling at Dryden on each of the return legs.

The Auxiliary Power Unit (APU), necessary to electrically power and condition the aircraft on the ground with the engines off, was reported inefficient. The APU was also needed to start the engines, and a ground generator was not available at Dryden for this function.

For this reason, the Company's Operations Control had predicted that the aircraft would keep an engine running in Dryden even during refueling, a procedure called "hot

refueling”.

At 7.49 am the plane took off for the first leg with 11 passengers on board. The weather in Dryden was still acceptable while in Thunder Bay it was getting worse. While they were in the air, Operations Control, from the Company's headquarters in London, called the Company agent in Dryden asking to contact the commander by telephone after landing. At 8.19, 13 minutes late, the plane stopped in the apron keeping the right engine running. Mills stayed aboard and Morwood went down to call Operations Control.

The staff informed Morwood that conditions at Thunder Bay were below operating limits and that the aircraft was to remain in Dryden pending any improvement but when Morwood reminded them that it had to keep an engine running and that it would consume fuel, they agreed to resent and to decide what to do within 15 minutes.

When Morwood called for the second time, the weather in Thunder Bay was still below limits but seemed to be improving, so it was decided to leave with an expectation of an improvement; if it had not happened, the flight would have diverted to Sault Ste Marie, as foreseen by the schedule.

At 8.50 am with 30 passengers on board and 20 minutes late on schedule, the Fokker 28 took off from Dryden. During the 40-minute flight, conditions in Thunder Bay actually improved and the plane landed regularly, arriving at the Thunder Bay terminal at 9.30am, the same 20 minutes late.

For the return flight to Winnipeg, designated 1363, Operations Control had scheduled 55 passengers from Thunder Bay to Dryden and 52 from Dryden to Winnipeg. Sault Ste Marie would still have been the alternate airport and the plane would have had 7,170 kg of fuel on board. This would have avoided refueling at Dryden.

But after completing refueling and with passengers on board, the crew was informed that due to the cancellation of an Air Canada flight, 10 passengers had to be re-protected on Flight 1363 to Dryden, bringing the total to 65, which is a full plane.

However, this meant that the maximum allowable take-off weight was exceeded and Morwood told the Thunder Bay Air Canada staff that he could not carry any more passengers. Then Air Canada turned to the Air Ontario Operations Control which ordered the commander to reduce the amount of fuel to embark passengers.

This decision was frustrating for the captain who had to suck 1300 kg from the tanks with a further delay of 35 minutes.

At 11.55, an hour late, Flight 1363 took off for Dryden where weather conditions were worsening and the latest forecast was of freezing rain mixed with snow.

Half an hour later, on approach to Dryden, the pilots were informed that a precipitation front with sleet was approaching, but the runway was still dry and free of any snow deposits. At 11.40 the aircraft landed while the snow was intensifying while melting on contact with the runway.

6.1 Back to Dryden

The plane stopped near the terminal and the left engine was turned off again. Eight passengers got off the plane while another seven were boarded for Winnipeg. Meanwhile, the snow was intensifying with increasingly thicker and thicker flakes. A few minutes

after he parked the plane, Morwood got off to call Operations Control and a heated discussion ensued which Morwood ended by slamming the phone.

Meanwhile, in the cockpit, Mills was keeping up to date on the evolution of the weather in contact with the Kenora station (which operated traffic and weather information services for Dryden airport) and announced that a heavy snowfall.

Neither pilot went out again for an inspection lap around the aircraft.

When the doors were closed and the left engine was restarted, a thin layer of ice and snow began to cover the ground and snow deposits of about 10 millimeters were accumulating on the wings. At 12.03 the Fokker 28 began taxiing as the snowfall increased in intensity; Mills called Kenora again to coordinate their flight.

Just then Kenora reported the presence of a Cessna, 4 miles south of Dryden heading urgently for landing due to the problems it was encountering with weather conditions. So the crew of Flight 1363 was asked to wait and Morwood, after alerting the Dryden airport, intercommed the passengers to inform them of this other delay, starting with a resigned: "Well, folks, this isn't quite our day!"

A few minutes later the Cessna landed as the snow became heavy. Morwood informed the airport that they were entering the runway for take-off and Mills received instructions from Kenora for the instrumental route to follow to Winnipeg.

They set the flaps to 18 degrees, the take-off configuration, and Morwood advanced the throttles to take off from Dryden runway 29, one hour and ten minutes behind schedule.

The snowfall continued to intensify as the plane accelerated slower than usual. The track was already under at least half an inch (12 mm) of slush of snow and ice.

After about a kilometer of running the aircraft was seen, by some people from the airport, spinning without leaving the ground, then the nose was again seen lowering towards the runway as the race continued.

Near the end of the 6,000-foot runway, the plane rolled its nose up again and this time seemed to come off the ground in a very upturned attitude.

6.2 The disaster

Shortly thereafter the aircraft, hitherto visible with difficulty through the heavy snowfall, disappeared entirely from view amid the treetops beyond the airport boundary. The high-powered engines were heard for a moment, then a moment of silence followed by a blaze of fire and a dense cloud of mushroom-shaped smoke, which rose from the point where the aircraft had disappeared.

The head of the fire service called the Kenora station to inform of the disaster and ask for the intervention of the police and ambulances and the activation of the municipal emergency plan.

Shortly afterwards, along the provincial road, the airport rescue vehicles reached the access to the road that led into the woods towards the place where the plane must have fallen.

They managed to locate the area where some parts of the wreck were burning. Some survivors had wandered off through deep snow, and several had quite severe burns and injuries. It was 12.20.

The police, ambulances and medical staff arrived at the entrance to the road and, having reached the area adjacent to the wreck, quickly intervened on the most seriously injured while about twenty survivors, who could walk in the path open in the snow, were directed to the vehicles. stop on the provincial road. Most of them were not equipped for the existing critical climatic conditions. Some were boys. Later twenty-two bodies were recovered, including those of pilots and a flight attendant.

6.3 First surveys

An investigation team from the Canadian Aviation Safety Board arrived in Dryden the morning after the disaster.

The dynamics became immediately evident from what investigators found on the ground.

The Fokker 28, failing to gain altitude after the take-off rotation, ended up in the dense pine forest that covered the slope west of the runway end.

The remnants of the disaster lay about a kilometer away from the runway. The fuselage was reduced into three sections.

At the moment of impact, the landing gear was moving towards retraction and the flaps were extended to around 26 degrees. An obvious desperate attempt by the pilots to keep the plane in the air.

Examination of the engines and their accessories revealed that they operated normally and were capable of delivering power at full throttle until impact and that they had probably gone from take-off thrust to maximum thrust (full throttle throttles) after rotation.

The de-icing systems of the engines were inserted.

It was determined that the weight of the aircraft at takeoff and the position of the center of gravity were within limits.

6.4 The Commission of Inquiry

The witness evidence, the meteorological conditions, the fact that the plane had not been de-iced before departure, the delay in take-off while it was snowing heavily, having ascertained from declarations and documentation that the plane was structurally intact and fit to fly, confirmed to the Canadian Aviation Safety Board that the Fokker-28 did not fly after rotation due to snow and ice accumulated on the wings, a condition capable of losing up to 50% of the aircraft's sustaining capacity.

But why had an airline commander with Morwood experience who had flown all his life in this harsh climate, an individual known for precision and compliance, had made this fundamental mistake?

Why did co-pilot Mills, with Arctic flight experience and command experience himself, let himself be carried away by Morwood's haste to take off?

On board were two other captains among the passengers, both worried about the contaminated condition of the wings, which they could observe from the windows. Why did they feel they did not have to intervene, even though their lives and that of their families were in danger? Flight attendants and other passengers were also concerned

about the snow accumulating on the wings, one passenger with aviation experience even pointed this out to flight attendant Katherine Say.

At this point in the investigation, responsibility for the investigation was removed from the Canadian Aviation Safety Board. The questions raised by the Air Ontario Fokker disaster, the concerns about the airline and the anomalies found at different levels of the Canadian aviation system (including the Department of Transportation), prompted the Privy Council of Canada to appoint a special commission with the task of investigating all the possible causes that could have contributed to the disaster, reporting them to the Council itself together with the recommendations deemed necessary for the safety of Canadian air transport.

The Commission should have conducted not only a full investigation into the disaster, but also the entire aviation system.

Judge Virgil P. Moshansky was called to chair the Commission, assisted by a large number of legal and technical experts, who was empowered to investigate as broadly as he deemed necessary.

The Commission heard 166 witnesses and examined 1343 evidence, some consisting of very large documents. The public hearings, held in Dryden and Toronto between June 1989 and January 1991, revealed numerous shortcomings of the Air Ontario company, the general aviation industry and the Department of Transportation (Transport Canada).

In his preface to the four volumes of the final report, Judge Moshansky stated: "It is my well-founded hope that the work done by this Commission will serve as a catalyst for change . . . I am convinced that if the report is carefully considered and the recommendations . . . accepted and implemented in a timely manner, an important contribution will be made to the safety of the company. Canadian aviation."

6.5 From active leaks to latent leaks

Technical findings of the investigation clearly indicated that Captain Morwood had made a mistake in taking off with ice and snow deposited on his wings. But what was the reason for this decision?

The investigation of accidents involves an analysis of the behavioral aspects of man in relation to the event, of the errors that are the immediate cause of the disaster, or of the omissions that did not prevent the event from taking place.

In this case, the Commission went much further and discovered that the organizational and regulatory deficiencies that had allowed the development of the Dryden disaster.

6.6 Deficiencies in government regulation

The Commission found the following shortcomings in the Canadian Department of Transportation:

There were no valid criteria for training airline inspection personnel.

Frequent turnover of inspectors had led to the hiring of poorly trained personnel.

Air Ontario's operations were not kept under control during the merger with Austin Airways and during the start of jet aircraft operations, as a result, the company op-

erated the Fokker 28 for a few months without a minimum equipment list (Minimum Equipment List) regularly approved.

There were no defined rules regarding the essential elements for the airworthiness of aircraft.

The criteria for the functions of the flight operations director, chief pilots and control pilots had not been defined.

There were no guidelines regarding the need to carry out de-icing operations on aircraft before departure.

There was no particular license or specific training for flight dispatchers, that is, the assistance and support staff of the flights.

An audit on Air Ontario was planned at the time, but was delayed pending the changes that were in place. When it was finally done, the most significant aspect was left out, the delicate transition to operations with the Fokker 28.

6.7 Management deficiencies

Air Canada, although it had a direct interest in the business of Air Ontario Inc, did not expect it to operate to its own high level of standard. Many problems could have been avoided if Air Canada had played a more active role in controlling the franchise sold to Air Ontario Inc.

During the merger of Air Ontario ltd with Austin Airways and throughout the strike period, a lot of animosity arose between the pilots of the two airlines.

The Air Ontario people used to call the other "bush pilots" while they called the Air Ontario pilots "the 401 pilots" referring to the highway connecting Windsor to Montreal, via Toronto.

6.8 Lack of experience on aircraft with jet engines

There was no experience with jet engine aircraft at Air Ontario. With the acquisition of the Fokker 28, the expertise to manage the new sector was sought outside. An experienced pilot was hired for the post but resigned a month later. He he declared that he had assessed that he could not work without the necessary support of resources. Air Ontario chose to use pilots with little Fokker 28 experience and no previous experience on large medium to short range jets.

6.9 Internal operational deficiencies

Operations with the Fokker began without an operations manual and without a minimum equipment list (it was only approved a few months later). Therefore, at the time, the crews did not have adequate operational arrangements.

Air Ontario's Aircraft Operations and Handling Control Center did not provide crews with assistance similar to what was done at Air Canada. This gave its flight assistance staff specific training and the crews with precise technical and operational guidelines. For example, they could not have flown an aircraft with an inoperative on-board auxiliary generator to operate on an airport without a grounded generator.

6.10 Training difficulties

Crew training on the Fokker 28 was done in the United States at Piedmont Airlines. But Piedmont itself had recently been absorbed by USAir which, in order to standardize its operations, was forced to update the ex-Piedmont pilots to its own procedures.

Since Air Ontario had not yet produced its own aircraft user manuals, pilots returned from training with manuals they had from Piedmont or USAir.

Another problem with the USAir - Piedmont merger was that the Fokker 28 simulator was overloaded and not all Air Ontario pilots were able to use it. Those who were able to use them, as soon as they qualified, trained the others directly on the aircraft.

Air Ontario's chief pilot for the Convair 580, he was also project manager and chief pilot for the Fokker 28. He simultaneously held many other training and management positions. Also, during the strike, he had to fly a lot, and he too had little experience on either type of aircraft.

6.11 Summary of the results

The Commission decided to establish that, from all the evidence gathered, factors had emerged which had progressively deteriorated the efficiency of the Fokker 28's crew and which had increased its level of stress. The mere change in one of these factors could have disrupted the chain of events that led to the disaster.

Here are some examples.

A better criterion for the use of the aircraft by the operations center would have prevented operations on Dryden that day.

More stringent regulations and appropriate training on the effects of surface contamination by snow and ice, including the phenomenon of "cold soaking", would have gained a greater understanding of the degradation of aerodynamic performance.

A crew resource management (CRM) training program could have contributed to more effective communication between pilots and flight attendants.

It was evident that Morwood, due to the accumulation of delays, fatigue and frustrations, had concluded that it was best to leave Dryden as soon as possible, because he was pressured by the passengers' need not to miss connections in Winnipeg.

Besides, Morwood and Mills already had plans for the following day.

If they had shut down both engines in Dryden, it would have been necessary to wait for the dispatch, in another flight, of a compressor to start the engines. With the result of a delay that is difficult to assess and a detrimental effect on the company's image.

Seeing the snow fall and melt on the parking lot ground, the pilots had hoped the same would happen on the wings. The surface of the wings, colder due to the previous exposure in flight to very low temperatures, from the particular type of snow that was falling, caused the formation of grainy ice, a phenomenon that had not been considered, probably because it was not known to the pilots.

A further possibility of rethinking in order not to take off, had been propitiated by the delay to wait for the landing of the Cessna. Visibility was further reduced due to the intensification of the snowfall but, at this point, stress, annoyance and frustration had, fatally, the upper hand on the judgment of the crew.

6.12 The Commission's conclusions

The Commission concluded that the commander had decided to take off, despite the accumulated snow on the wings, as he believed that it was not adherent to the surface and would be blown away during the take-off run.

Commander Morwood was responsible for this decision but it was equally clear that the entire air transport system had prepared a situation in which the commander did not have all the elements to make the correct decision.

The oversight by the authority (Transport Canada - Aviation Regulation Directorate) had been inadequate. Within the body (TC), the concern about the overly burdensome commitments by its inspectors for the operations and maintenance of the carriers dates back to 1982. The shortage of adequate personnel in these two inspection areas (maintenance and operations) had been identified by a Commission of Inquiry into Flight Safety, since 1979.

There were insufficient resources for inspections of regional carriers and inspections of new aircraft. These often flew without the requirements of the regulations having been ascertained. Several times the supervisory committees had reported this state of affairs and the consequent tendency to take management shortcuts to meet the numerous commitments of the institution. This situation could be described in the same words even at the time of the Dryden disaster. The problem did not consist only in the lack of qualified personnel, but in the complete disorganization of available resources, engaged in bureaucratic tasks, preparation of reports to justify actions postponed or not carried out, communications of resumption of actions, use of untrained personnel, use of executives in operational activities to temporarily resolve crises due to shortage of inspectors, and many other aspects frequent in any state agency where bureaucracy prevails over efficiency.

Therefore, the Canadian Aviation Regulation Directorate was not adequately equipped to perform the intended functions. The warning signs that had appeared since the early 1980s and repeated in subsequent years had had no effect. By now the need for immediate recruitment and preparation of suitable staff was well known, but there had been no requests or authorizations in this regard.

The lack of planning and management skills had put all the staff in a position not to be able to carry out the tasks assigned.

Had the working group been enabled to perform their duties effectively, many of the factors that had caused the Dryden disaster would have been avoided.

In conclusion, the tasks performed by a pilot depend on a whole series of mental processes with sequential characteristics ordered in space and time, except for a series of variables. On the other hand, the way he can perform them is much more complex; it will depend on a continuous balance between the intention and the mental scenario within which that intention evolves. The scenario is, in turn, influenced by the conditions of the autonomous system at that particular moment.

Therefore, even under standard conditions, the brain functions at its best but suffers from a whole series of influences that have little or nothing to do with the context of that particular action.

Here it is worth dedicating some in-depth passages to this organ which, like others, has evolved over a very long period of time, while retaining basic patterns shared in the various animal communities, from the most archaic to the most modern ones.

7 The brain

7.1 General considerations

In relation to the interests of the scientific community over time, it will be noted that at some point the attention shifted from genetics to neuroscience, with various types of insights into the biology of the mind (Kandel *et al.*, 2012). The human brain weighs around 1.5 kg but has almost unimaginable qualities and capabilities. These are more than one hundred billion of cells, neurons, grouped in circuits/networks with high levels of interconnections, capable of giving rise to behaviors, some voluntary, others automatic, which enable us to operate “at best” in contexts where we are sometimes actors, sometimes spectators. In other words, we engage in behaviors that, in themselves, are not inherited situations. Actually, what is inherited is DNA¹¹; therefore, genes encode proteins, essential for the development and regulation of the nervous circuits that underlie behavior.

Now, we are talking about a new neuroscience, that of the mind, as a result of studies of cognitive processes, emotions and animal and human behaviors. In the field of life sciences, the final target is represented by the mental processes that allow us to perceive, act, learn and remember.

7.2 The operating unit of the brain. The neuron

The neuron (Fig. 9, left) is a cell made up of a body (soma) whose diameter is between 10 and 50 μm with its nucleus, an axon that continues with axon terminals and dendrites. The axon can be covered with a myelin sheath which modifies some bioelectrical characteristics (conductivity). Like all cells in the organism, the neuron is able to separate electrical charges (cations and anions) in the thickness of its membrane. In other words, it behaves like an accumulator and, as such, is able to store bioelectric energy (Fig. 9, right) and redistribute it in the form of information, when certain conditions are met.

¹¹Deoxyribonucleic acid (DNA) is a nucleic acid that contains the genetic information necessary for the biosynthesis of ribonucleic acid (RNA) and proteins. Chemically, DNA is a double stranded organic polymer whose monomers are called nucleotides. Nucleotides are made up of three basic components: a phosphate group, a pentose sugar (deoxyribose, also called deoxyribose) and a nitrogenous base that binds to deoxyribose with an N-glycosidic bond. There are four nitrogenous bases that enter the formation of nucleotides: adenine, thymine, cytosine and guanine (uracil is present in RNA instead of thymine). DNA can be globally defined as a polynucleotide double chain (A, T, C, G), antiparallel, oriented, complementary, spiralized, informational.

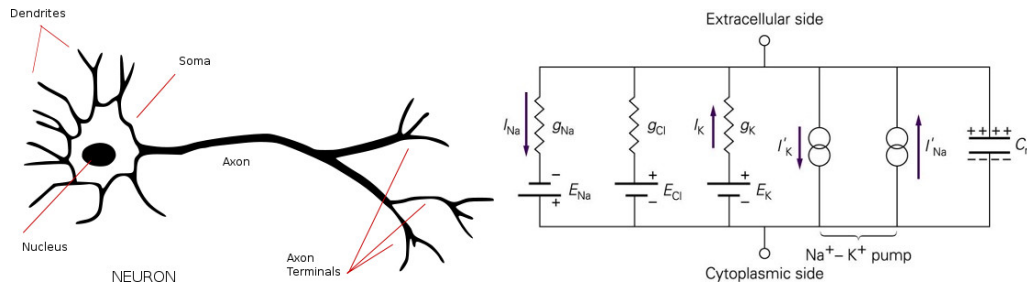

Figure 9: (Left) Schematic drawing of a neuron (shape being variable). (Right) Equivalent circuit of the neuronal membrane. The circuit-elements include the pathways that represent the ion channels for the Na^+ , K^+ and Cl^- and the short-circuit pathways equivalent to the cytoplasm and extracellular fluid. The phospholipid bilayer and the conductive solutions of the intracellular and extracellular surfaces provide the electrical capacitance (C_m)¹² to the membrane.

Ionic currents in transit through the membrane of a neuron reach a condition of dynamic equilibrium, giving rise to a battery with a potential difference (ΔV) between its poles equal to about -80 mV. From a bioelectrical point of view, the membrane behaves like a circuit capable of self-charging, through the use of particular Na^+/K^+ pump¹³. The neuron is also defined as an excitable cell, as it

¹²The membrane capacitance results from the fact that the plasma membrane acts as a capacitor: the phospholipid bilayer is a thin insulator separating two electrolytic media, the extracellular space and the cytoplasm. The membrane capacitance is proportional to the cell surface area and, together with the membrane resistance, determines the membrane time constant which dictates how fast the cell membrane potential responds to the flow of ion channel currents. Membrane capacitance is the electrical capacitance associated with a biological membrane, expressed in units of Farads. The electrical capacitance of a biological membrane results from the membrane composition of a bilayer of mostly phospholipids that form an insulating matrix to which proteins are attached or embedded. The amount of this capacitance (C_m) is Q (charge)/ V (electric potential) across the membrane. If it is considered per unit area, $C_m = C/S \approx 10^{-2} \text{ F m}^{-2}$, where F is the unit of capacitance (Farad).

¹³The Na^+/K^+ pump. It operates in the thickness of the cell membrane and is responsible for the maintenance and variations of the potential through the active transport of ions. All cells in resting conditions present, at the level of the plasma membrane, a separation of electrical charges, consisting of an excess of positive charges on the external surface and negative charges on the internal one. The separation of these charges is responsible for a membrane potential at rest, which normally is around -70 mV. The membrane is able to maintain this separation of charges because it acts as a selective barrier of permeability, allowing the passage of some ions such as potassium, sodium, chlorine and calcium, and preventing the diffusion of others (organic anions). The passage of diffusible ions through the membrane occurs through channels or pumps. In resting conditions, the concentration of K^+ ions is higher inside the cell and that of Na^+ ions outside. The ions therefore tend to passively diffuse through the membrane under the action of the electrical and concentration gradient. In particular, in the nerve fiber there is a pump, called the ATP-dependent sodium-potassium pump which, by exploiting the energy from the hydrolysis of ATP, causes the release of 3Na^+ ions for every 2K^+ ions that enter. The application of a stimulus on a nerve fiber changes the permeability of the membrane to Na^+ ions. This creates a flow of positive charges of Na^+ ions towards the inside of the cell, responsible for a local modification of the membrane potential. When this modification reaches a minimum value (called threshold), through the opening of special voltage-gated sodium channels, a massive

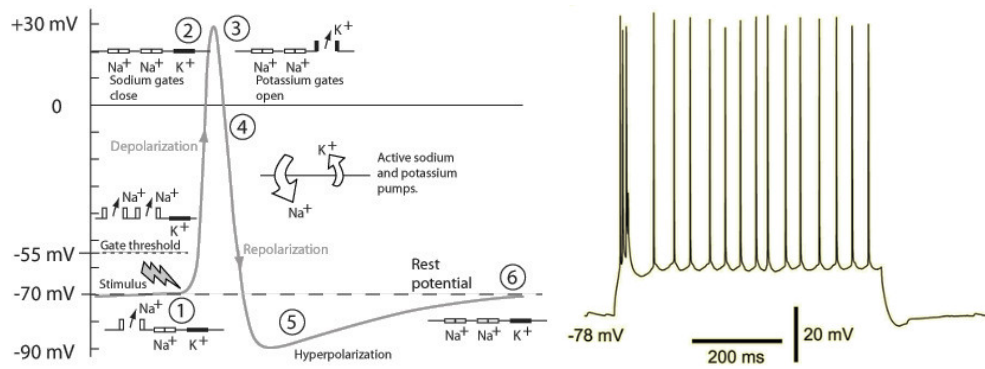

Figure 10: (Left) Schematic representation of an action potential: (1) onset, (2) depolarization and peak, (3) peak and decay, (4) repolarization, (5) posthumous hyperpolarization (not all neurons show this phenomenon). Morphology and evolution of the action potential (spike) are caused by variations in the permeability of chemo-dependent and voltage-dependent ion channels (Na^+ , K^+), located in the thickness of the neuron's cell membrane. Duration ranges from 800 μsec to 1.2 msec. (Right) Bursts of action potentials recorded from a cultured mammalian neuron.

is able to respond to chemical or electrical eustresses, as an effect of information in transit, generating electrical potentials, the action potentials (Fig. 10).

These are depolarizations that last a few milliseconds and push the ΔV value up to values around +45 mV. These depolarizations, defined as action potentials, are endowed with self-propagation without decrease, with frequencies around 700-900 Hz, along the entire length of the axon with velocities of about 120 m/sec (233 NM/h) up to its terminals, where they give rise to the quantum release of chemicals, neurotransmitters/neuromodulators (Li Volsi, 2016). The latter will, in turn, affect other neurons with which they are connected, via synapses¹⁴.

inward shift of Na^+ ions occurs, which causes a reversal of the membrane polarity and the formation of a potential called action potential. Immediately afterwards, the voltage-dependent channels for sodium close and the opening of voltage-dependent channels for potassium occurs, causing a flow of K^+ ions towards the outside. In this way there is a rapid return towards the values of the potential at rest.

¹⁴Synapse. In neurophysiology, the functional point of contact between two nerve cells or, more precisely, between the neuritic termination of one and the pyrenophore (S. axo-somatic), a dendrite (S. axo-dendritic) or neurite (S. axo-axonic) of the other, in order to ensure the passage of excitation from one neuron to another and in only one direction. In the so-called electrical synapses, present in invertebrates, the transmission of the impulse occurs through a simple flow of current along protoplasmic bridges that unite the two elements. In the so-called chemical synapses, characteristic of mammals, the phenomenon is more complex: the action potential at the level of the termination of the first neuron (presynaptic termination) essentially determines the opening of the synaptic vesicles which release the neurotransmitter in the space between the two structures (subsynaptic space or synaptic cleft); the neurotransmitter is picked up by specific receptors located on the membrane of the second neuron (postsynaptic membrane), causing physical-chemical modifications that generate a current capable of propagating throughout the membrane. The neuromuscular synapse is the junction between motor neuron and muscle at the level of the motor plate, where the transmission of the impulse takes place with the modalities of

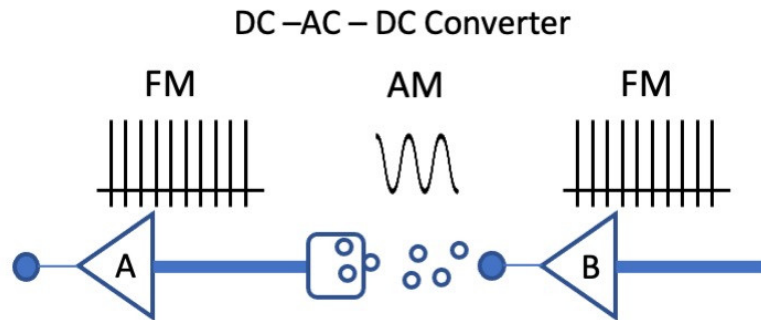

Figure 11: Scheme of the synaptic release of the neurotransmitter by neuron A. The quantum release of the molecules is a function of the firing frequency of A. At postsynaptic level, these molecules will cause on neuron B a firing of action potentials with a frequency proportional to the quanta released. (A digital-to-analog converter is a device that converts a digital signal into an analog signal. An analog-to-digital converter is the converter that performs the reverse function.

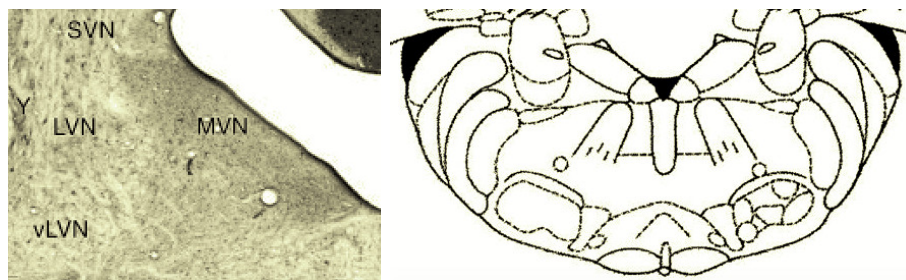

Figure 12: (*Left*) Mammalian histological preparation with particular reference to the vestibular nuclei complex. SVN: Superior vestibular nucleus; MVN: Medial vestibular nucleus; LVN: Lateral vestibular nucleus; vLVN: Lateral vestibular nucleus, ventral division. Note the different level of aggregation of neurons and the different size. (*Right*) The same frontal plane as A in a more expanded drawing.

Therefore, the information is transferred through neuronal chains, where frequency modulated signals produce the release of molecules whose quantity (amplitude) will be a function of said discharge frequency (Fig. 11).

In summary, sets of neurons form aggregates/networks, at increasing levels of organization in which information travels to other neuronal networks. Functionally homogeneous networks of neurons give rise to the so-called nuclei (Fig. 12).

chemical synapses: the extracellular space of the neuromuscular synapse is called the synaptic cleft.

7.3 The sensory receptors

The central nervous system is also equipped with sensory components, the receptors, which provide the information necessary for the design of behavioral responses following different types of stimuli (Kandel *et al.*, 2012; Kaas and Gardner, 2008). In the context of the stimulus-receptor interaction, some further clarification must be made, concerning the adaptation to the stimulus by the receptor. For this reason, the receptors are classified as fast and slow adaptation to the stimulus. The rapidly adapting, or phasic, receptors are those that, during the application of a stimulus, respond, generating a transduction potential and possibly an action potential, only in the “transient phases”, that is, at the beginning and at the end of the stimulus. If we wear a pair of glasses, we realize their presence (weight exerted) only at the beginning; then the sensation ceases even if the stimulus is present. Only when we remove them will we be aware of the termination of the weight stimulus.

Conversely, slow-adaptive or tonic receptors respond with a change in the potential of the receptor that persists throughout the duration of the stimulus with a slight tendency to adapt. A pressure of 30g distributed over 4mm², exerted on the index finger of the right hand, will be felt for as long as the weight is placed on the finger.

On a macroscopic scale, the responses produced by the receptors may consist of scenarios, ideas, motor acts and behaviors whose complexity will depend on the quantity of receptors that have been activated. Quality and quantity of sense receptors is pushed to the point that we are capable of accurate discrimination in distinguishing and characterizing signals, external or internal to our body, of different nature. In fact, a proprioception and an exteroception are defined.

In the field of exteroception, perception consists in becoming aware of a reality that is considered external, through sensory stimuli, analyzed and interpreted through intuitive, psychic and intellectual processes.

Consider an aircraft; it can be perceived because seen or due to the noise produced by its engine/propeller or due to the smell of its exhaust gases or due to the vibrations it generates. Hence the concept of multimodal perception, the advantages of which are extraordinary. The pilot becomes familiar with these perceptions, to the point of building very complex spatial-temporal memory schemes. For this reason, he is able to report about a standard engine noise or to report anomalous conditions. In this regard, the use of standard aeronautical headsets or headphones equipped with filters capable of attenuating some of the perceived frequencies is still the subject of debate.

The correct functioning of both types of receptors (slow and fast adapting) is the essential prerequisite for the safe and efficient conduct of a flight. Let's not forget that the pilot finds himself operating within a “system”, the aircraft, which moves in the three dimensions of space. By acting on the control bar, he modifies the inclination of the tail planes, rudder or ailerons. The resulting effects may be roll, induced roll, yaw, pitch or combined actions. As for the maneuvers, they are divided into standard: dive, turn, take-off and landing and

acrobatic: inverted flight, knife turn, looping, tonneau, Immelman turn, half S, Cuban eight, autorotation, stall and escaped.

Leaving aside the acrobatic maneuvers, actions on the handwheel, on the bar or on the joystick and on the pedal board allow the pilot to navigate according to very specific rules, the rules of flight, on the basis of a plan previously drawn up and communicated to the air traffic control bodies, in accordance with the provisions of Annex 11 of the [ICAO](#).

8 Air navigation

Understanding how animals can navigate, using the earth's magnetic field, is a very difficult undertaking ([Mouritsen, 2012](#); [Hiscock et al., 2016](#); [Li Volsi, 2014](#)). Humans, with rare exceptions, are navigators with little hope of reaching a goal, unless we have aeronautical maps or a Global Positioning System. Another series of problems relating to navigation also concerns some parameters such as the sense of gravity, attitude in space with respect to the gravity factor, acceleration, deceleration. On the other hand, while navigation on the earth's surface takes place on two axes (x, y) , air navigation develops in a three-dimensional environment in which the presence of the z axis enriches its evolution with further variables. Wind, air temperature, dew point, barometric pressure, relative humidity are non-negligible parameters.

We can redefine navigation as a result of the effects exerted by the pilot on the controls, while he is "solicited" by the management of the parameters previously described. Today's aircraft navigate through complicated guidance systems that record accelerations and rotations. The degree of precision of these systems is now very high, thanks to the presence of laser and computer gyroscopes. Despite this, in the animal world the principles that govern inertial guidance have a remarkable "dating", as can be observed in vertebrates, which have been using similar systems for over 500 million years. The problem, however, has even more ancient origins and invertebrates are reliable witnesses. To be more precise, three-dimensional navigation began in bacteria equipped with dipoles capable of perceiving magnetic fields ([Li Volsi, 2014](#)).

In vertebrates, including humans, it is the vestibular system that deals with the management of inertial guidance. It has five sense organs (three semicircular canals and two otolithic organs, a utricle and a saccule) housed in the inner ear and capable of acquiring information that detect linear and angular accelerations of the head ([Baloh and Honrubia, 1990](#); [Highstein and Holstein, 2006](#); [Kandel et al., 2012](#)) (Fig. 13).

This information intervenes in keeping the eyes fixed during the movement of the head, as well as in adequate posture, and helps to influence the perception of our movement and the surrounding space, thanks to the transmission of information relating to the gravitational field in which we are included. More specifically, the semicircular canals are responsible for detecting the rotation of the head, the otolithic organs detect linear accelerations, including the static ori-

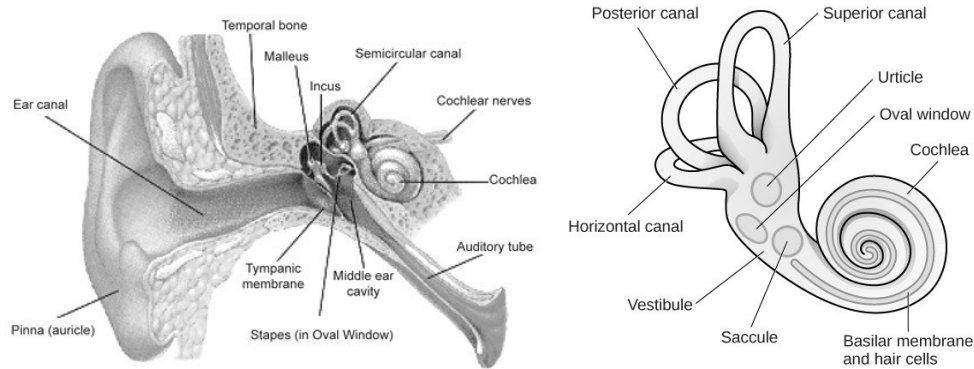

Figure 13: Vestibular system. (Left) Frontal section of the ear. (Right) The major sensory organs of the vestibular system are located next to the cochlea in the inner ear. These include the utricle, saccule, and the three semi-circular canals (posterior, superior, and horizontal).

entation of the head with respect to the gravity factor. The cells responsible for these functions are called hair cells; they are present both in the domes of the semicircular canals and in the otolithic organs (Fig. 14A). The information produced by the deformation of the hair cells present in the ampoules of the semicircular canals reach the complex of vestibular nuclei, located at the brain level, between the pons and the bulb. Figure 14 schematically depicts the complexity of synaptic input impinging in the vestibular nuclear complex.

In the context of coordinated eye motility, the neuronal circuits in which vestibular sensors are inserted give rise to vestibular-ocular reflexes (Fig. 15) (Dieterich and Brandt, 1995; Sugawara *et al.*, 2019), whose function is to stabilize the eyes and the body when moving head. Conversely, the otolithic reflexes compensate for the linear movement and deviations of the head.

These reflexes have limits; the representation of the movement is imperfect, as they detect the initial part and sudden variations, but have limited effectiveness in compensating for the effects produced by the translation movements that extend into the head at constant speed or rotational movements that are prolonged at speed constant angular.

Within the brain, system variables can induce changes in the information in transit in the various neuronal networks, capable of altering the functioning of the nerve networks responsible for implementation processes (motor system and endocrine system). Furthermore, the more transit stations there are relative to this information, the more likely it is that it will be modified. In other words, an information generated by the receptor/sensor X, of mode B, intensity 3, duration 7 will reach its final neuronal/muscular/secretory target with probable modifications of the above parameters (Fig. 16).

Even at the level of the vestibular circuits, information born from the activation of the hair cells present in the ampullae, utricle and saccule, can undergo variations in intensity and duration.

In this regard, it should be noted that the complex of vestibular nuclei is

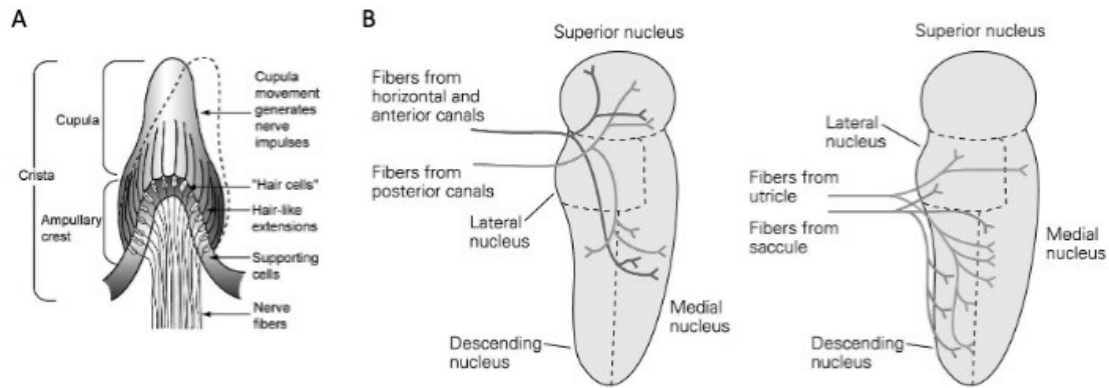

Figure 14: (A) Scheme of hair cells contained in the ampullary crest. (B) Input-output circuits within the complex of vestibular nuclei. Note how the information (afferents) coming from the semi-circular canals, utricle and saccule, after having affected the vestibular neurons, are retransmitted to other neuronal nuclei involved in the control of ocular motility and of the spinal and supra-spinal motor systems. (Redrawn after [Kandel et al., 2012](#)).

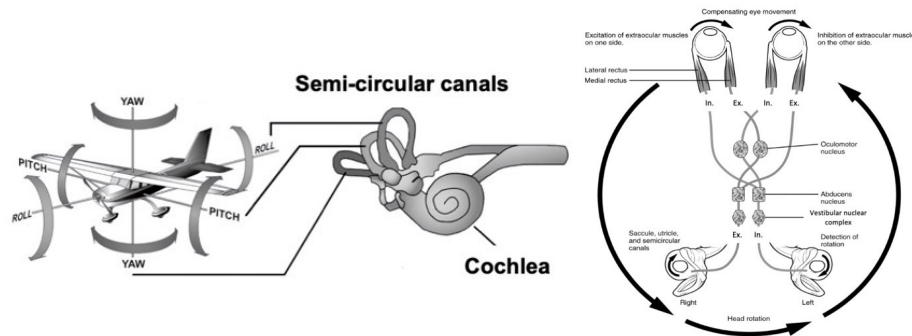

Figure 15: (Left) Scheme of the rotation axes of an aircraft. (Right) vestibulo-ocular circuit. Ex.: Excitatory pathway; In.: Inhibitory pathway.

reached not only by nerve fibers from primary glutamate afferents, but also by numerous encephalic nuclear formations ([Soto et al., 2013](#)). Among them we remember fibers from the locus coeruleus, which release noradrenaline ([Schuerger and Balaban, 1993](#)) and from fibers from the raphe nuclei, which use serotonin as a transmitter ([Halberstadt and Balaban, 2007](#)) (Fig. 17).

Research conducted on the subject confirms, in fact, that both serotonin (Fig. 18) and noradrenaline (Fig. 19) are able to modify the response pattern produced by glutamate on the neurons of the vestibular nuclei ([Li Volsi et al., 2001](#); [Barresi et al., 2009](#)).

The diagrams in Figs. 16, 17 and the histograms in Figs. 18, 19 express a concept.

When more information in transit converges on a nervous structure, the latter will operate algebraic summations between what tends to make it more active towards the target structures and what tends to mitigate the effects it can produce on them.

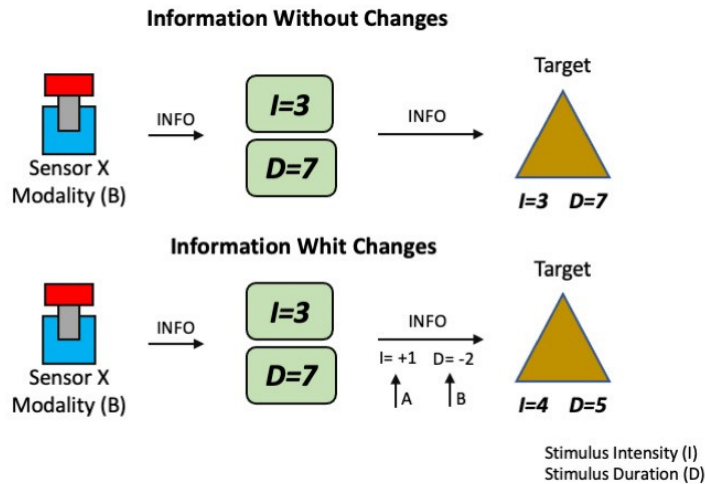

Figure 16: (Up) Information generated by the sensor/receptor X, of B modality, reaches the Target without any modification of the parameters I and D. (Down) Information generated by the sensor/receptor X, of B modality, reaches the Target with the parameters I and D modified. It will have a greater intensity but a shorter duration.

In order to complete the reasoning, another issue must be considered. The function of the complex of vestibular nuclei is to exercise control over postural adjustments and eye movements in relation to head movements.

When the information coming from the vestibular apparatus reaches the vestibular nuclear complex, it will be subject to interference by information that has a completely different nature. It is known, in fact, that the neurons of the raphe nuclei, through which they release serotonin, intervene in the regulation of the sleep-wake cycle, thus influencing the circadian rhythms.

In turn, the neurons from the locus coeruleus carry information relating to attention, the sleep-wake cycle, learning and pain perception, the genesis of anxiety and the regulation of mood and appetite.

In conclusion, a pilot who finds himself managing his aircraft will have to deal with his “autonomic moment”. In other words, his vestibular function, subjected to stresses deriving from the type of maneuver in place at a given moment, will be framed in a much broader context, where it will be subject to interference varying in intensity and duration. It follows that his organism must always be in the best psycho-physical conditions, which can minimize “intrusions” that can be classified as not homogeneous with the context. Yet another and important clarification concerns the functioning of the hair cells. They are receptor units that operate within the semicircular canals and otolithic organs, immersed in the endolymphatic fluid. When they are no longer stressed by the inertial motion of the endolymphatic fluid, they stop flexing and stop functioning. This is a condition that follows, when the garment maintains slight angular variations that last over time. At this point, a new set-point or zero condition of the head is established which, in reality, no longer corresponds to its standard

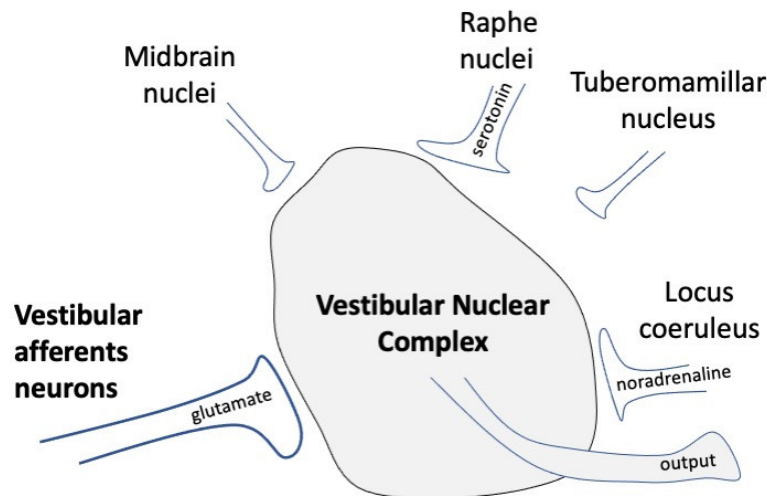

Figure 17: Main afferents to Vestibular Nuclear Complex. terminals from other nuclei are depicted with the neurotransmitter released by them.

zero position with respect to the gravity factor. The pilot has placed himself in a new condition; he is in spatial disorientation. In adverse weather conditions or poor visibility this phenomenon will be particularly critical.

9 Spatial disorientation

Spatial disorientation ([Skybrary Aviation Safety](#)) is defined as the inability of a pilot to correctly interpret aircraft attitude, altitude or airspeed in relation to the Earth or other points of reference.

Spatial disorientation, if not corrected, can lead to both loss of control and controlled flight into terrain. The possibility of becoming spatially disorientated is hard-wired into all humans. In fact, it is the proper functioning of our spatial orientation system, which provides the illusion; and because this is a system we have learnt to trust, it is particularly difficult for some people, in some circumstances, to accept that their orientation isn't what it appears to be. Despite the capability, accuracy, reliability and flexibility of modern flight displays and instrumentation, pilots can still find themselves questioning what the aircraft is telling them, because the "seat of their pants" or "gut feeling" is saying something else. No one is immune.

Therefore, learning, and regularly refreshing one's knowledge, about spatial disorientation, how and why it happens, how to recognize it, and what to do to about it, is essential in improving and maintaining flight safety.

Being in flight means that pilot may be subject to motion, speed, forces and variations in gravity (both positive and negative) which our orientation system will be unfamiliar with. This can lead to a false perception of its orientation and relative movement.

Spatial disorientation is more likely to occur when there is no visible horizon - on a dark night or in Instrument Meteorological Conditions (IMC). If malfunc-

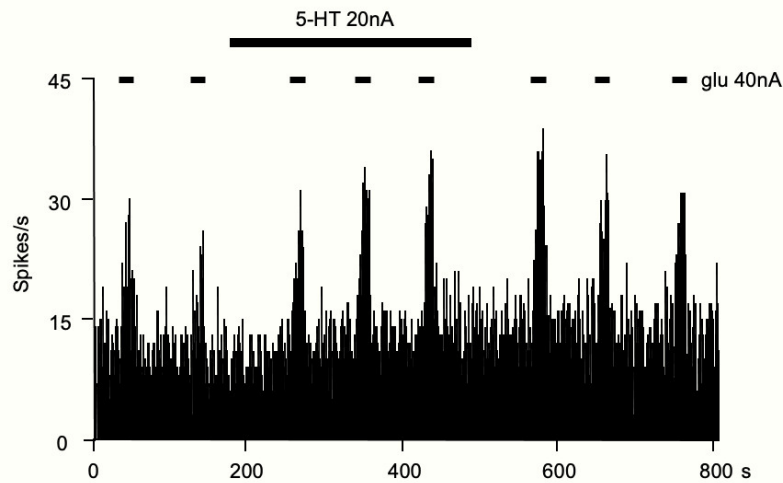

Figure 18: Effects of long-lasting serotonin (5-HT) application on the excitatory responses evoked by glutamate (GLU) in the vestibular nuclei. The histogram illustrates the number of spikes fired by a neuron belonging to the vestibular nuclear complex. Each column indicates the number of spikes fired in a period of 5 s. The horizontal bars above the histograms indicate the duration of ejection of the indicated drugs at the given current. The mean firing rates recorded in the absence of any drug application represent the background activity. The GLU-evoked excitations are indicated by an increase in the firing rate under the horizontal bars. Effects observed were reversible. Courtesy of [Li Volsi *et al.* \(2001\)](#).

tioning flight instruments, high workload or a breakdown in CRM are present, then the risk of spatial disorientation is increased.

There are two main types of spatial disorientation “illusions” that humans are susceptible to in flight: Somatogravic (Fig. 20) - experiencing linear acceleration/deceleration as climbing/descending; Somatogyral –not detecting movement or perceiving movement in a different (mostly opposite) direction to reality.

Both are a result of the normal functioning of the vestibular system, in the relatively unusual environment of flight.

Any sensory modality alone can provide ambiguous sensations on postural orientation and body movement. For example, the information provided by the visual system alone does not allow us to distinguish the movement of our body from that of an object. At the station, if sitting inside a train, when we see another train moving next to ours, we cannot understand if it is our train that is moving or the one next to it.

Vestibular information can also be ambiguous. A first reason for ambiguity arises from the fact that they are located on the head; therefore, they provide information on the acceleration of the head but not of the other parts of the body. The visual system assumes not negligible importance, when we consider that the information generated by the visual receptors provide in advance cognitive elements on potentially destabilizing situations. In this way, they contribute to

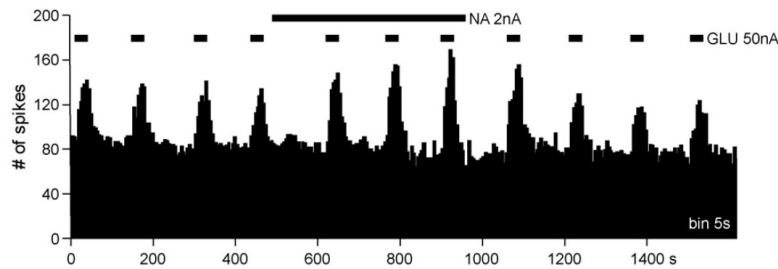

Figure 19: Effects of long-lasting noradrenaline (NA) application on the excitatory responses evoked by glutamate (GLU) in the vestibular nuclei. The histogram illustrates the number of spikes fired by a neuron belonging to the vestibular nuclear complex. Each column indicates the number of spikes fired in a period of 5 s. The horizontal bars above the histograms indicate the duration of ejection of the indicated drugs at the given current. The mean firing rates recorded in the absence of any drug application represent the background activity. The GLU-evoked excitations are indicated by an increase in the firing rate under the horizontal bars. Effects observed were reversible. Courtesy of [Barresi et al. \(2009\)](#).

orientation in the surrounding environment.

The posture control system makes use of a body scheme that incorporates internal models for the control of balance ([Massion, 1994](#); [Brandt, 1991](#)). Due to its mechanical complexity, our body needs its coherent representation and its interaction with the surrounding environment. This allows, for example, that a person is able to touch his nose with the tip of the index finger with his eyes closed. Already at the beginning of the twentieth century, the neurologist Henry Head described the body scheme as a dynamic system within which its space-time characteristics are continuously updated. According to this assumption, a person can adequately plan motor strategies if he has information not only on the relationship between the different body segments, but also if he has information on the mass and inertia of each segment and an estimate of the external forces that act on the body, including gravity.

Another non-secondary component concerning the body scheme consists in a model of the sensory information expected following a movement. If the sensory information received from the nervous system does not correspond to that expected, disorientation or symptoms typical of motion sickness may appear; something that occurs in the microgravity environment, characteristic of space flights. However, with continuous exposure to the new environment, the model is gradually updated, until the expected sensory information harmonizes with that which is received; at this point, the spatial disorientation will disappear.

The problem relating to spatial disorientation has always been the subject of in-depth studies aimed at improving the safety of pilots in flight. The Italian Air Force has set up a special body, the Higher Institute for Flight Safety, with the aim of investigating this topic.

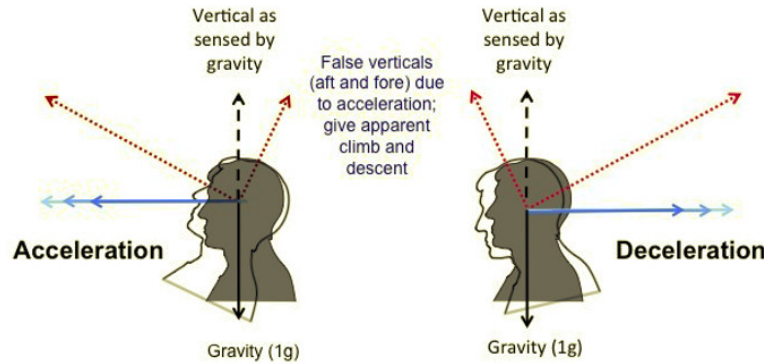

Figure 20: Somatogravic Illusion of Climbing. The illusion of climbing is most likely experienced when accelerating at take-off, initiating a go-around with full power, pulling out of a dive, levelling off from a climb and entering (or tightening) a turn. From [Skybrary Aviation Safety](#).

A few years ago, the Chief of Staff of the Air Force, Gen. Pasquale Preziosa spoke on the subject, dealing with the topic of Space Disorientation in the bi-monthly periodical Flight Safety ([Preziosa, 2013](#)).

We report below the subsequent paper on the same issue of that journal, by Magg. [Verde \(2013\)](#), which we considered very significant.

Flight Safety has dramatically improved in recent years. These advances have taken place not only for the arrival of innovative technologies and the improvement of man-machine interfaces, but also for the joint efforts among pilots, flight surgeons, engineers, ground staff, flight safety committees and other government agencies.

The research and developments in this sector have been invaluable but any improvement and industrialization of aircraft design corresponds to an increase of new machines performance that makes obsolete the man-machine systems, requiring more innovative solutions from the point of view of “cognitive ergonomy”.

Accidents caused by pilot errors continue to occur and investigation boards are always performing a complex job, often due to the lack of facts, with the risk that the “Root Causes” may remain hidden. Pilots tend to label as Spatial Disorientation (SD) any event they cannot recognize with an immediate causal/rational explanation.

All pilots, in fact, from gliders to fast jets, can fall into SD occurrence; this is due to the fact that the basic task of a flying pilot is primarily perceptual in nature and his perception (i.e. the processing of sensory inputs) while often unusual and highly variable, on the other end it should be accurate and fast in the interest of efficiency and safety of flight.

The perceptual conflict between the senses and the brain in flight is quite common since the orientation in the air is much more complex than that on the ground. When a pilot takes off, he finds him/herself in front of a problem of “orientation in three dimensions”, with or without direct reference to the ground.

On the surface, however, the pilot has a large amount of direct means of reference, rarely discordant for his/her orientation with respect to earth. Basically problems are

“two-dimensional” in nature and include the distance and direction from a flat surface. The orientation with respect to physical forces complies with the orientation with respect to objects.

In the air, however, the elements needed to determine the position (and thus the orientation) must be three-dimensional and are, very likely, limited. Furthermore pilots, regularly subjected to various acceleration forces, can have illusory sensations that make uncertain their position in space. Precise orientation in relation with physical forces no longer conforms to the orientation to objects.

Thus, pilots must learn the complex perceptual task of determining his location, making use of secondary reference elements supplied to them by the instruments. Information from the instruments lead, sometimes, to confusion because there is often a conflict with the subjective sensory feeling. The perceptual task varies greatly from one type of flight to another and is particularly challenging with new generation aircrafts.

Type of Spatial Disorientation (SD). *SD can manifest itself in various ways, in each case related to the particular phase of flight and the actions taken by the pilot to counteract the illusory sensations received. Most researchers classify SD as follow:*

- *SD type I (Unrecognized);*
- *SD type II (Recognized);*
- *SD type III (Incapacitated) for some researchers.*

In SD type I, the pilot does not recognize that his perception of orientation is incorrect and, therefore, does not perform any maneuvers to correct aircraft attitude and/or recovery. From a statistical point of view, 80

SD type II is characterized by the recognition of the conflict between “natural” body sensory inputs and the reading of the instruments inside the cockpit. However, the recognition of SD state may be delayed or hindered by various “attentive” interferences. The correct management of the phenomenon is to immediately realize and report the condition of disorientation, recover as soon as possible the visual dominance through the instrumental management of the aircraft and to continue flying according to instrument procedures overcoming, through instruments reading, the neuro-sensorial conflict that originated the disorientation process.

SD type III can be considered a variant of the SD type II in which the pilot, while identifying the state of disorientation, is unable to perform any corrective action to recover aircraft attitude.

This occurs due to a sudden loss of the ability to “drive” or a behavioral response known as “freezing” at the controls, with inability to perform any corrective actions. The three types of SD provide different preventive interventions: for type I, it is necessary to act in terms of secondary prevention, i.e. early detection, through instruments cross-check, or by automatic recognition and warning systems.

For the type II, in which the DS is recognized, prevention aims to sharpen the ability to implement quickly and proper procedures for aircraft attitude recovery. In type III, where the DS is recognized but the pilot is unable to react, prevention is based on the

availability of fully automatic recovery systems (activated by the computer) or semiautomatic recovery system (activated by the pilot).

Physiological importance of the sense organs in spatial disorientation The body orientation on Earth surface is achieved by using information coming mainly from visual receptors, vestibular and auditory and by subcutaneous and muscular "proprioceptive sensors". Signals obtained by these sense organs are sent to the central nervous system and processed. This allows to detect the position and movement of the body in relation to a system consisting of the natural horizontal plane of Earth's surface and from the vertical one of the gravity force.

In this reference system, the eye is the predominant organ: the accurate perception of the orientation for a pilot largely depends on the correct interpretation of visual stimuli from outside and from the instruments on board. The pilot who has well-defined external visual information, rarely encounters SD phenomena, but it is a different story when flying with poor visual references, where he is strongly obliged to refer to the on-board instruments. From a structural point of view the brain possesses two different ways of processing visual information, depending on whether the fovea (focal vision) or from the peripheral retina (environmental vision).

With daylight images are processed using focal vision, in a central area of the retina (fovea) formed by the "cones" (retinal receptor cells), which allow to capture detailed information about shape and colors; these information are then transmitted to the brain where interpretation and identification of the image take place. The direct vision of aircraft instrumentation constitutes a practical example of the focal vision.

The environmental vision, occurs in the presence of low levels of brightness and uses information coming from the peripheral areas of the retina formed exclusively by "rods", which allows a less defined surrounding environment, however, being sensitive to moving objects is useful to correlate the position of the pilot with the surrounding environment.

In the absence of adequate visual information, the vestibular system detects linear and angular accelerations of the head, becomes the driving system for the natural orientation which, however, cannot always provide correct information to the pilot on the movement and attitude of the aircraft, not being designed and calibrated for the acceleration forces of flight environment.

The "labyrinth", in the inner ear, consists of the semicircular canals, the "utricle" and the "sacculle", which, through specific receptors, provide the information relating to the angular and linear acceleration.

Additional information, useful to the orientation, are those that come from the "proprioceptive" system, consisting of mechanoreceptors located in the skin, muscles and joints. During the flight, the pilot is frequently subjected to acceleration that cause shifts in posture. Such movements determine compressive effects on various parts of the body, which stimulate the receptor system by providing a set of useful information to spatial orientation.

Conclusions. Starting from the simple awareness that disorienting phenomena occur very often in flight, especially in extreme environments, the effort of the scientific com-

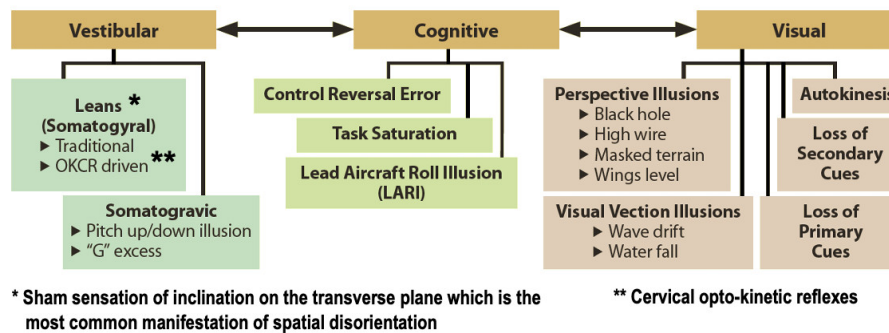

Figure 21: Relationships between vestibular, cognitive and visual function. Within each function the related criticalities are indicated.

community should be oriented towards two main directions: provide specific training to the Flight Personnel and improve man-machine interaction.

The new pilot training processes in this field are precisely aimed at increasing the knowledge on SD, improving the skill to recover from this illusions and increasing the ability to maintain the overall “situational awareness”. These processes require activation of complex mental sequences, partly conscious and partly unconscious, aimed at eliminating attentive errors (bad habit, distraction, channelized attention, negative transfer, time warp).

On the other hand the development of next-generation aircraft and the use of technologies, such as Head Up Displays or Night Vision Goggles, have significantly reduced the operational fatigue of the pilot, but they have not simplified the cognitive component or management of onboard systems, increasingly numerous and complex.

Spatial disorientation is connected to the flight but the incidence of episodes is favored by the lack of basic knowledge and the lack of precise occurrence reports related to real events in flight. The scientific community is fully aware of not being able to reset the rate of incidents/accidents related to SD; it is also well known that new forms and types of disorientation will follow and accompany future new aircraft flight characteristics.

The diagram shown in Fig. 21 summarizes complexity and interconnections between vestibular, cognitive and visual function.

10 The Pilot: a powerful biological device with some weak points

Evolution of biological systems places human beings at the apex of a position of near perfection. Organs and systems of which they are made up work in great harmony, giving rise to a complex community of systems that are only apparently independent. Surprisingly, the collaboration between organs and systems is continuous and is not always appreciable on a macroscopic scale.

A few examples will serve to clarify some of these “collaborations”. After a meal without salt, one often has the desire to drink; the reason is simple: the relationship between solvent (body water) and solute (salt) has been altered. In other words, the osmotic pressure has changed. It is a parameter that expresses,

in a solution, the increase in solvent particles that occurs by osmosis when a semipermeable membrane is interposed between a solution and a pure solvent. Hence, the feeling of thirst that leads to take a certain amount of water to re-balance the relationship in question. This will occur but with the addition of a new problem; the body finds itself having an excess of water and salt which it must get rid of. The kidneys will do this by producing appropriate urine in the quantity and type of soluble components.

Analyzing the different moments of what happened, the following can be summarized.

As a rule, a flavorful food is preferred over a bland one. The sight of certain foods, imagining their taste, and noting the smell emanated, arouses a sense of appetite in certain areas of the brain. From here, the primary intervention of the visual and olfactory receptors is evident. The intake of the above food produces a sensation of thirst, due to the activation of a category of receptors, called osmoreceptors, located in a nerve formation called the hypothalamus.

The osmoregulation and excretion apparatus, *i.e.* the kidney, provides for rebalancing the solvent/solute ratio. In the meantime, the cardiovascular system had to manage a new situation generated by an increase in the total volume of circulating fluids, by adjusting some cardiovascular parameters, such as arterial pressure and vessel diameter. Not only that; some components of the endocrine system have also been involved, having to manage the release of molecules to manage this new condition.

What has been described represents an example of involvement of organs and systems, aimed at restoring certain types of balance, in this case of an osmotic nature. In conclusion, the brain dictated a certain behavior which then involved other systems for the purpose of rebalancing.

11 Brain and behavior

The scientific literature proposes two alternative ways of conceiving the relationships between the brain and behavior. Furthermore, the brain has functionally distinct regions and this is inferred from studies carried out in order to locate the brain areas involved in the cognitive faculties. Affective traits are also mediated by specialized brain-localized systems. Finally, the concept that mental processes are the final products of the interactions that are established between elementary units of analysis located in the brain is now well established (Kandel, 1976; Ross, 1984; Bear, 1979).

The quality of mental processes and consequential acts also depends on the level of performance of the human machine. In this regard, it is good to consider two relevant phenomena that affect the operation of a pilot: the circadian rhythm and the sleep-wake cycle.

The circadian rhythm (Fig. 22), in chronobiology and in chrono-psychology, is a rhythm characterized by a period of about 24 hours. The term "circadian", coined by Franz Halberg, comes from the Latin language *circa diem* and means

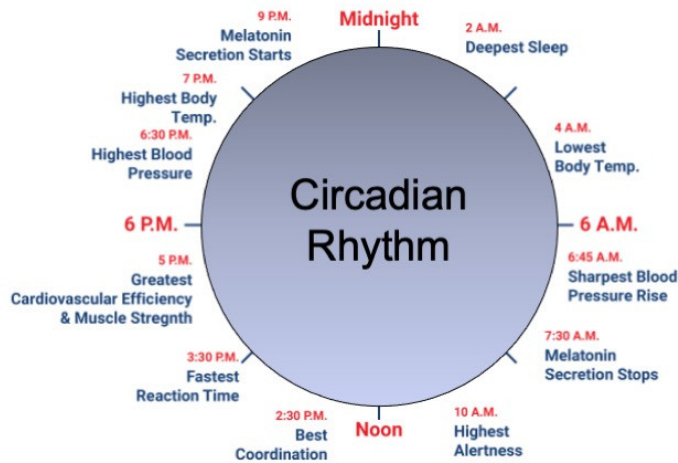

Figure 22: Circadian rhythms are physical, mental, and behavioural changes that follow a 24-hour cycle. These natural processes respond primarily to light and dark and affect most living things, including animals, plants, and microbes.

“around the day”.

The circadian rhythm consists of the cyclical variations that involve biological activities every day. It is a sort of biological clock with a period of 24 hours which is characterized by being a complex internal system responsible for cycles concerning blood pressure, body temperature, muscle tone, heart rate, sleep-wake rhythm and others manifestations related to the endocrine system.

The organisms that populate the planet earth, including humans, have an internal biological clock that varies, with a “real clock”, as the hours pass: this mechanism, in fact, adapts to the different phases of the day, regulating key functions such as hormone levels, sleep and metabolism. For this reason, when it is misaligned with respect to the external environment, it produces effects on a psycho-physical level. Jet lag is an example of this¹⁵ which, due to a sudden change in the time zone, has negative effects on the body as it creates an alteration of its own circadian rhythms.

12 The sleep

It is a periodic need of the body, defined as a state of rest as opposed to wakefulness. Various definitions indicate sleep as “a periodic suspension of the state of consciousness”, during which the organism recovers energy; state of physical and mental rest, characterized by the temporary detachment of consciousness and will, by the slowing down of the neurovegetative functions and by the partial interruption of the subject’s relationship with the environment, essential for restoring the organism. Like wakefulness, in fact, sleep is an active physiological

¹⁵Jet-Lag is a set of disturbances that affect those traveling by plane, and therefore very quickly, over distances that involve changes in one or more time zones in a short time.

process that involves the interaction of multiple components of the central and autonomic nervous system.

In fact, although sleep is represented by an apparent state of rest, during this state complex activities take place in the brain that cannot be explained only as a simple state of physical and psychic rest.

Two fundamental characteristics distinguish sleep from the waking state: the first is that during sleep a temporary perceptual barrier is created between the conscious world and the external world, the second is that a sensory stimulus of a certain level (for example a loud noise) can overcome this barrier and wake up the sleeping subject.

Adequate sleep is biologically imperative for infant brain maturation and life sustaining. The psycho-physical health of the individual depends on the quality and duration of sleep. Sleep disorders, such as insomnia, are present in many psychiatric diseases, in which sleep deprivation has a significant impact on the person's quality of life.

Sleep has a regular alternation of non-REM phases¹⁶ and REM consisting of cycles of similar duration (Table 4). After falling asleep, the subject progressively passes from stage 1 of non-REM sleep to stage 2, then passes to stage 3 or stage 4 slow wave sleep and then, between 70 and 90 minutes after falling asleep, the first REM sleep phase occurs and lasts about 15 minutes. At the end of the first phase of REM sleep, the first cycle ends and lasts approximately 80 to 100 minutes.

After the first cycle, others of rather constant duration follow but where REM sleep tends to increase in duration at the expense of non-REM sleep, in particular stages 3 and 4 (deep non-REM sleep) which become shorter. During the night, REM sleep ultimately makes up about 25% of the total sleep duration. It is possible that between the various cycles there are moments of wakefulness. The sleep period is represented graphically by means of hypnograms that illustrate the succession of the phases of wakefulness and sleep in relation to time. Today, instead of the subdivision into four stages, the three-stage nomenclature (N1, N2 and N3) adopted by the American Academy of Sleep Medicine in 2007 on the basis of the appearance and frequencies of the EEG oscillations is much more common, in which phase N3 brings together stages 3 and 4, both characterized by the same large slow waves, albeit in different percentages.

¹⁶Rapid eye movement sleep (REM sleep or REMS) is a unique phase of sleep in mammals and birds, characterized by random rapid movement of the eyes, accompanied by low muscle tone throughout the body, and the propensity of the sleeper to dream vividly. The REM phase is also known as paradoxical sleep and sometimes desynchronized sleep, because of physiological similarities to waking states including rapid, low-voltage desynchronized brain waves. Electrical and chemical activity regulating this phase seems to originate in the brain stem and is characterized most notably by an abundance of the neurotransmitter acetylcholine, combined with a nearly complete absence of monoamine neurotransmitters histamine, serotonin and norepinephrine.

Type of sleep	Characteristics of stage	Description of wave pattern
Awake	The state of being awake and alert with awareness.	Low-voltage high-frequency beta waves (> 14 Hz)
Drowsy	Reduced alertness and activity	Alpha waves prominent (8-13 Hz)
Stage 1	Transitional sleep	Theta rhythms (4-7 Hz)
Stage 2	Slightly deeper sleep	Spindles (initiated from the thalamus) and K complex and mixed EEG activity
Stage 3 and 4 (slow-wave/deep sleep)	Rapid eye movements classically absent with stage 4 (the deepest sleep stage) lasting 20-40 minutes	Delta waves (< 4 Hz)
REM	REM sleep featuring rapid eye movements	Sawtooth waves – low voltage high frequency

Table 4: Sleep stages.

13 The fatigue

It is a consequence of a material effort that is made to do a job or carry out any activity, and of which one feels the weight and then the fatigue; it can also depend on an intellectual effort. More generally, fatigue is not a pathology, but the manifestation of an over-load state. It is a symptom as frequent as it is generic in its definition, which describes various and non-specific sensations, such as muscle weakness, listlessness, loss of interests, etc., *i.e.* a series of situations or sensations that may be related to organic causes, and therefore more properly somatic, or psychic, or both.

Fatigue in aviation leads to not responding to some radio communication, manifests itself with burning and fatigue of the eyes, difficulty concentrating, forgetfulness about doing, such as the operation of an incorrect switch. The fatigued pilot tends to become fixated on only one element, tends to make gross errors, takes decisions in excessively long times, puts specific checks and/or actions.

The general adaptation syndrome is an organism response that is activated when it is subject to the prolonged effects of various stressful factors, such as physical, mental, social or environmental stimuli. The phases of stress begin with an alarm situation that produces autonomic responses on heart function, muscles and posture. A resistance phase follows, characterized by hormonal responses, with an increase in plasma of catecholamines (adrenaline and steroid

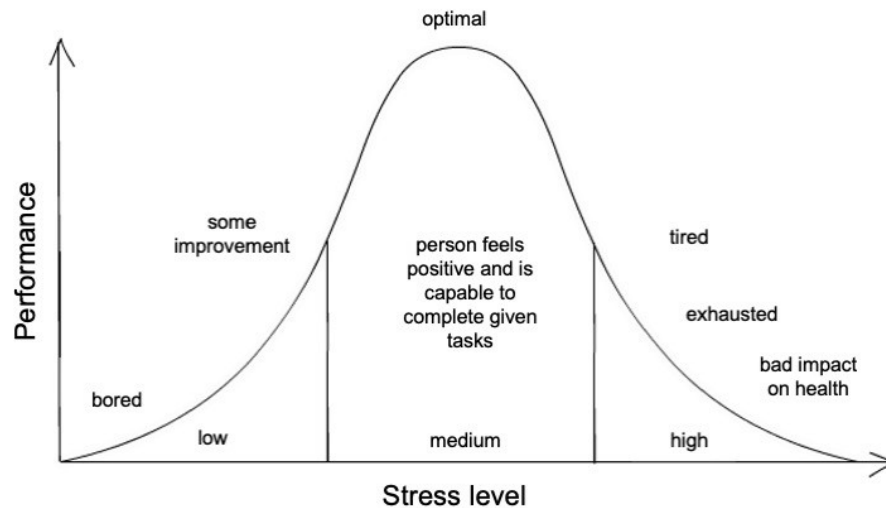

Figure 23: Stress levels, depending on the work done.

hormones). The last phase corresponds with exhaustion, that is, with psycho-physical collapse.

Stress and workload have detrimental effects on the pilot's performance. Nervous tension is also a source of stress. It appears as a wear that is often not felt by the subject but equally harmful (Fig. 23).

If the pilot is aware that he is under stress, he can respond in two ways: defending himself from it or facing it. Managing the stress associated with the difficulties of a pilot's tasks is part of a pilot's everyday life. His commitment must consist in determining priorities and evaluating what he can delegate both to others and to automatisms. Alternatively, he checks that the various routines are progressing according to the planned plans. Stress can accompany all phases of flight; from taking charge of the aircraft to its return to the lay-by. However, if smoke appears in the cockpit during the flight, the commander does not get lost or panic, but rather takes the emergency checklist and addresses the problem.

In conclusion, flying an aircraft is a courageous choice because it requires the Pilot to achieve a whole series of performances through responsible, meticulous and in many cases very hard work, in which there is no room for simple routines.

The pilot does not have anything supernatural, but he is aware of both his psycho-physical limits and his performances.

For this reason the Pilot must operate, referring to the acquired knowledge that led him to reach his position.

The pilot flies safely and this allows him to return home together with the crew and passengers.

To do this, he must fly a little further in time than the one read on the on-board clock.

Two or three minutes will be enough for him to deal with the after while he is dealing with the present.

A license to fly gives the Pilot privileges and not rights; and this is not a common occurrence, because flying is, in itself, a privilege and, as such, it should

not be wasted but kept.

Acknowledgements

We wish to thank all the staff of the Aero Club/ATO 0043 for the valuable contribution they provide in both administrative and technical activities of our organization. They make the didactic environments and the airworthiness of our aircrafts usable on a daily basis.

We are pleased to present administrative staff: Francesca Scalisi, Roberta Catalano and Salvo Briga; the technical staff Annamaria Pesce, Leonardo Cunsolo, Hector Gonzalez, Gaetano Rapisarda, Gaetano Rinaldi, Sebastiano Morace.

References

- Baloh, R. W. and Honrubia, V. (1990). *Clinical neurophysiology of the vestibular system*, volume 18 of *Contemporary neurology series* (F. A. Davis Co., Philadelphia), 2 edition.
- Barresi, M., Caldera, M., Grasso, C., Li Volsi, G., Licata, F., and Santangelo, F. (2009). *Noradrenergic modulation of neuronal responses to glutamate in the vestibular complex*. *Neurosci. Lett.* **464**(3), 173. doi:10.1016/j.neulet.2009.08.035.
- Bear, D. M. (1979). *The Temporal Lobes: An Approach to the Study of Organic Behavioral Changes*. In Gazzaniga, M. S., editor, *Neuropsychology*, pages 75–95 (Springer, Boston). doi:10.1007/978-1-4613-3944-1_4.
- Brandt, T. (1991). *Man in motion. Historical and clinical aspects of vestibular function. A review*. *Brain* **114** (Pt. 5), 2159. doi:10.1093/brain/114.5.2159.
- Chialastri, A. (2015). *Human Factor* (IBN Editore, Roma).
- Dieterich, M. and Brandt, T. (1995). *Vestibulo-ocular reflex*. *Curr. Opin. Neurol.* **8**(1), 83. doi:10.1097/00019052-199502000-00014.
- Dryden, *Neve e ghiaccio a Dryden*. <https://www.aerohabitat.org/airmanshiponline/1nov01/06-Neve%20e%20ghiaccio%20a%20Dryden.htm>, last accessed on 2022-04-16.
- Dyreson, M. (2020). *Optimizing human performance. A brief history of macro and micro perspectives*. *Kinesiol. Rev.* **9**(1), 4. doi:10.1123/kr.2019-0063.
- Halberstadt, A. L. and Balaban, C. D. (2007). *Selective anterograde tracing of the individual serotonergic and nonserotonergic components of the dorsal raphe nucleus projection to the vestibular nuclei*. *Neurosci.* **147**(1), 207. doi:10.1016/j.neuroscience.2007.03.049.
- Highstein, S. M. and Holstein, G. R. (2006). *The Anatomy of the vestibular nuclei*. In Büttner-Ennever, J. A., editor, *Neuroanatomy of the Oculomotor System*, volume 151 of *Progress in Brain Research*, pages 157–203 (Elsevier). doi:10.1016/S0079-6123(05)51006-9.
- Hiscock, H. G., Worster, S., Kattnig, D. R., Steers, C., Ye Jin, Manolopoulos, D. E., Mouritsen, H., and Hore, P. J. (2016). *The quantum needle of the avian magnetic compass*. *Proc. Natl. Acad. Sci. (USA)* **113**(17), 4634. doi:10.1073/pnas.1600341113.

- Hosseini, S. S. and Torghabeh, Z. J. (2012). *Major theories of construction accident causation models: a literature review*. Int. J. Adv. Eng. & Tech. **4**, 53. <https://www.ijaet.org/media/0006/6I10-IJAET1009264-MAJOR-THEORIES.pdf>, last accessed on 2022-04-16.
- ICAO, *International Civil Aviation Organization*. <https://www.icao.int/Pages/default.aspx9>, last accessed on 2022-04-16.
- Kaas, J. H. and Gardner, E. P., editors (2008). *The senses: A comprehensive reference*, volume 6: Somatosensation (Elsevier, Oxford).
- Kandel, E. R. (1976). *Cellular Basis of Behavior: An Introduction to Behavioral Neurobiology*. Books in psychology (W. H. Freeman, New York).
- Kandel, E. R., Schwartz, J. H., Jessell, T. M., Siegelbaum, S. A., and Hudspeth, A. J. (2012). *Principles of Neural Science* (McGraw-Hill, New York), 5 edition.
- Li Volsi, G. (2014). *Il funzionamento delle cellule e delle molecole* (EDISES, Napoli).
- Li Volsi, G. (2016). *The plasma membrane as a semipermeable barrier*. In Muro, S., editor, *Drug Delivery Across Biological Barriers*, chapter 3 (Jenny Stanford Publishing, Singapore).
- Li Volsi, G., Licata, F., Fretto, G., Mauro, M. D., and Santangelo, F. (2001). *Influence of serotonin on the glutamate-induced excitations of secondary vestibular neurons in the rat*. Exp. Neurol. **172**(2), 446. doi:10.1006/exnr.2001.7804.
- Massion, J. (1994). *Postural control system*. Curr. Opin. Neurobiol. **4**(6), 877. doi:10.1016/0959-4388(94)90137-6.
- Moshansky, V. P. (1992). *Final report of the Commission of inquiry into the Air Ontario crash at Dryden, Ontario, 1992* (Minister of Supply and Services Canada, Canada). Cat. No: CP 32-55/1-1992 E.
- Mouritsen, H. (2012). *Search for the compass needles*. Nature **484**(7394), 320. doi:10.1038/484320a.
- Petti, G. B., Iavarone, L., Pezzopane, A. G., Dentesano, R., and Silenzi, S. (2000). *La Strategia del Margine. Riflessioni sulla sicurezza del trasporto aereo* (Ed. Nuove Dimensioni, Roma).
- Preziosa, P. (2013). *Editoriale. Sicurezza del volo* **300**, 2. https://www.aeronautica.difesa.it/comunicazione/editoria/rivsicurezza/archivio_riviste/Documents/2013/Rivista300-2013.pdf, last accessed on 2022-04-16.
- Ross, E. D. (1984). *Right hemisphere's role in language, affective behavior and emotion*. Trends Neurosci. **7**(9), 342. doi:10.1016/S0166-2236(84)80085-5.
- Schuerger, R. J. and Balaban, C. D. (1993). *Immunohistochemical demonstration of regionally selective projections from locus coeruleus to the vestibular nuclei in rats*. Exp. Brain Res. **92**(3), 351. doi:10.1007/BF00229022.
- Skybrary Aviation Safety, *Spatial disorientation*. <https://skybrary.aero/articles/spatial-disorientation>, last accessed on 2022-04-16.
- Socha, V., Socha, L., Hanáková, L., Karapetyan, L., Valenta, V., Kušmírek, S., Pilmannová, T., and Olexa, P. (2020). *Effect of Psychological Training on Pilot's Performance*. Transp. Res. Proc. **51**, 252. doi:10.1016/j.trpro.2020.11.028. INAIR 2020: Challenges of aviation development.
- Soto, E., Vega, R., and Seseña, E. (2013). *Neuropharmacological basis of vestibular*

- system disorder treatment*. J. Vestib. Res. **23**, 119. doi:[10.3233/VES-130494](https://doi.org/10.3233/VES-130494). 3.
- Sugawara, T., Sakai, H., and Hirata, Y. (2019). *Vestibulo-ocular reflex characteristics during unidirectional translational whole-body vibration without head restriction*. Ergonomics **63**(1), 91. doi:[10.1080/00140139.2019.1683616](https://doi.org/10.1080/00140139.2019.1683616).
- Valente, P. (2008). *Elementi di Sicurezza del Volo* (Ed. Aeronautica Militare Italiana, Istituto Superiore per la Sicurezza del Volo, Roma).
- Verde, P. (2013). *Focus sul Disorientamento Spaziale*. Sicurezza del volo **300**, 4. https://www.aeronautica.difesa.it/comunicazione/editoria/rivsicurezza/archivio_riviste/Documents/2013/Rivista300-2013.pdf, last accessed on 2022-04-16.